



# M2M Core Networks

## 物聯網核心網路

# Low Power Wide Area Network (LPWAN)



# M2M Core Networks

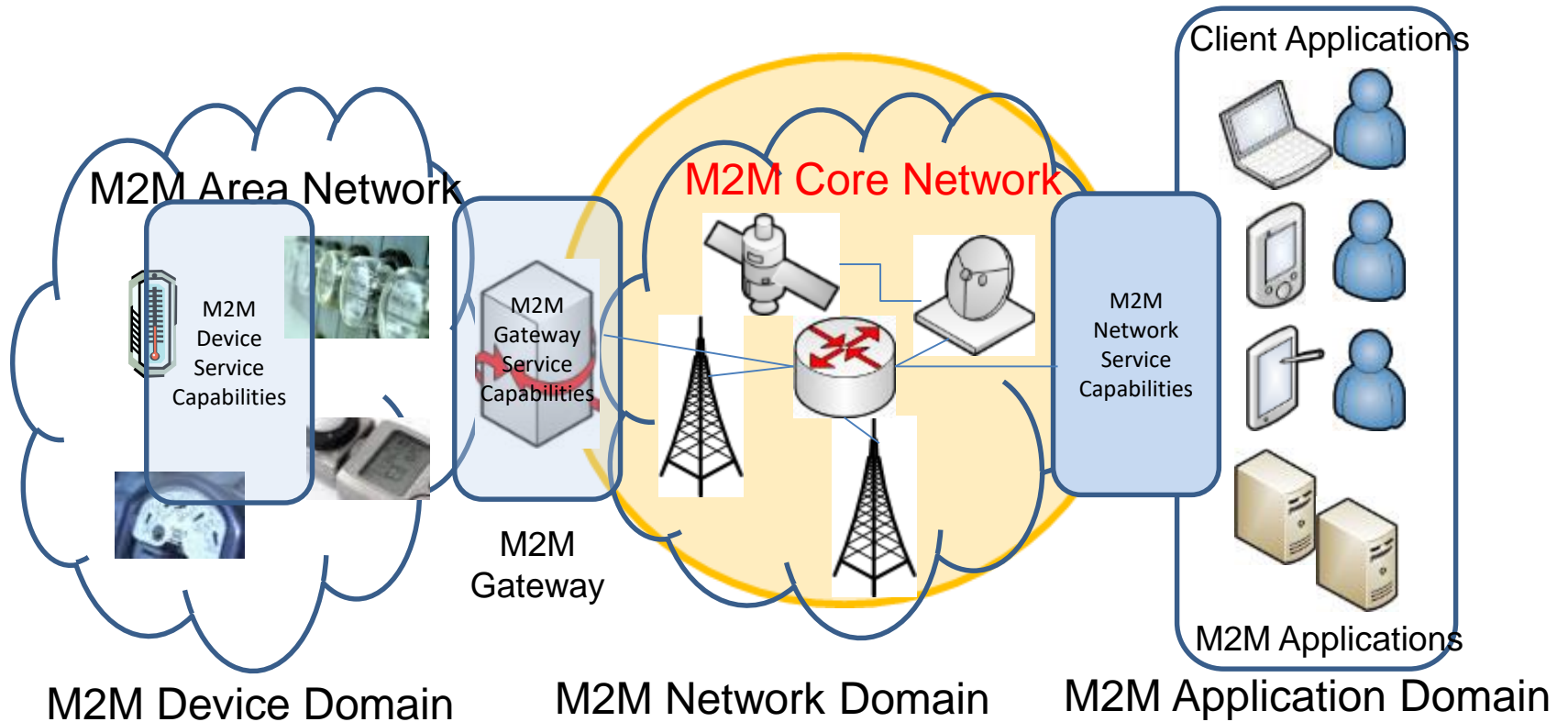

# LPWAN Impact to M2M Core

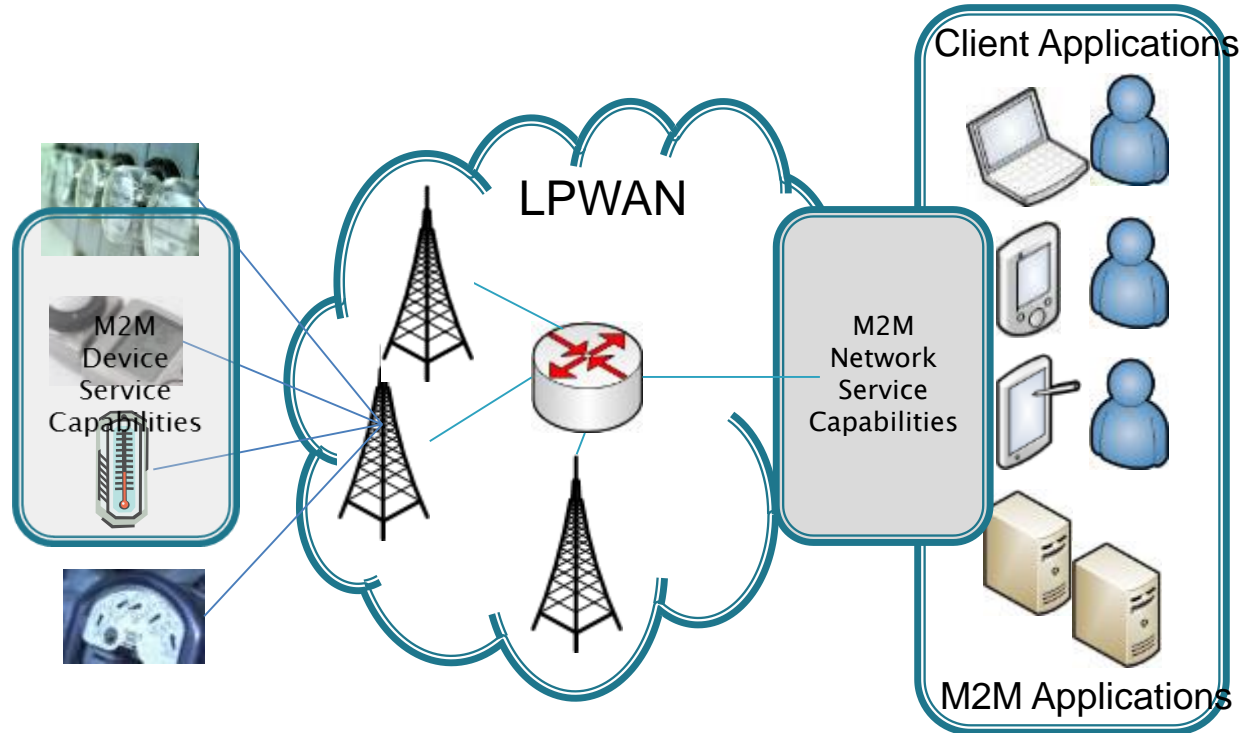

M2M Devices    M2M Network Domain    M2M Application Domain

LPWAN enables IoT devices to connect to backend systems without a gateway!



# Outline

- 3GPP Licensed Networks Evolution
  - EC-GSM
  - eMTC – LTE-M
  - NB-IoT
- Non 3GPP Unlicensed Networks
  - LoRaWAN
  - Sigfox
  - weightlessP



# Low Power Wide Area Network (LPWAN)

- Non 3GPP Unlicensed Networks (already deployed)
  - E.g. LoRaWAN, Sigfox, Neul and Nwave (based on Weightless-N) etc.
  - Most of these networks take advantage of ISM (industrial, scientific, and medical) unlicensed frequency bands.
- 3GPP Licensed Networks Evolution (released in 3GPP Rel. 13; under development)
  - eMTC – LTE-M (M: MTC - machine type communication) evolution
  - NB-IoT (evolved from NB-CIoT and NB-LTE)
  - EC-GSM



# LPWAN

- Long-range applications with low bandwidth requirements
- Emerging technology for M2M core network

# Importance of LPWAN

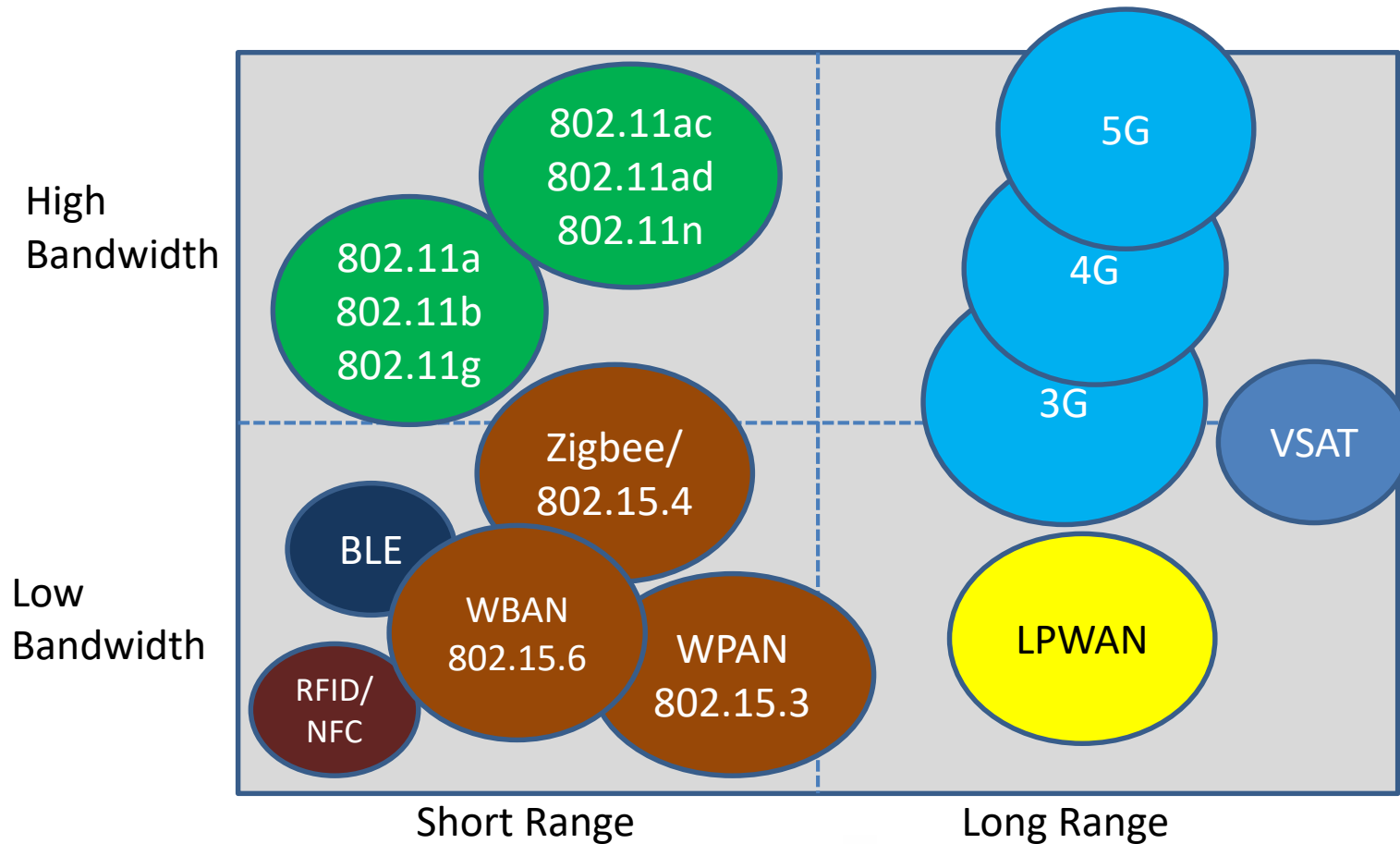



# Comparison with WSN/4G

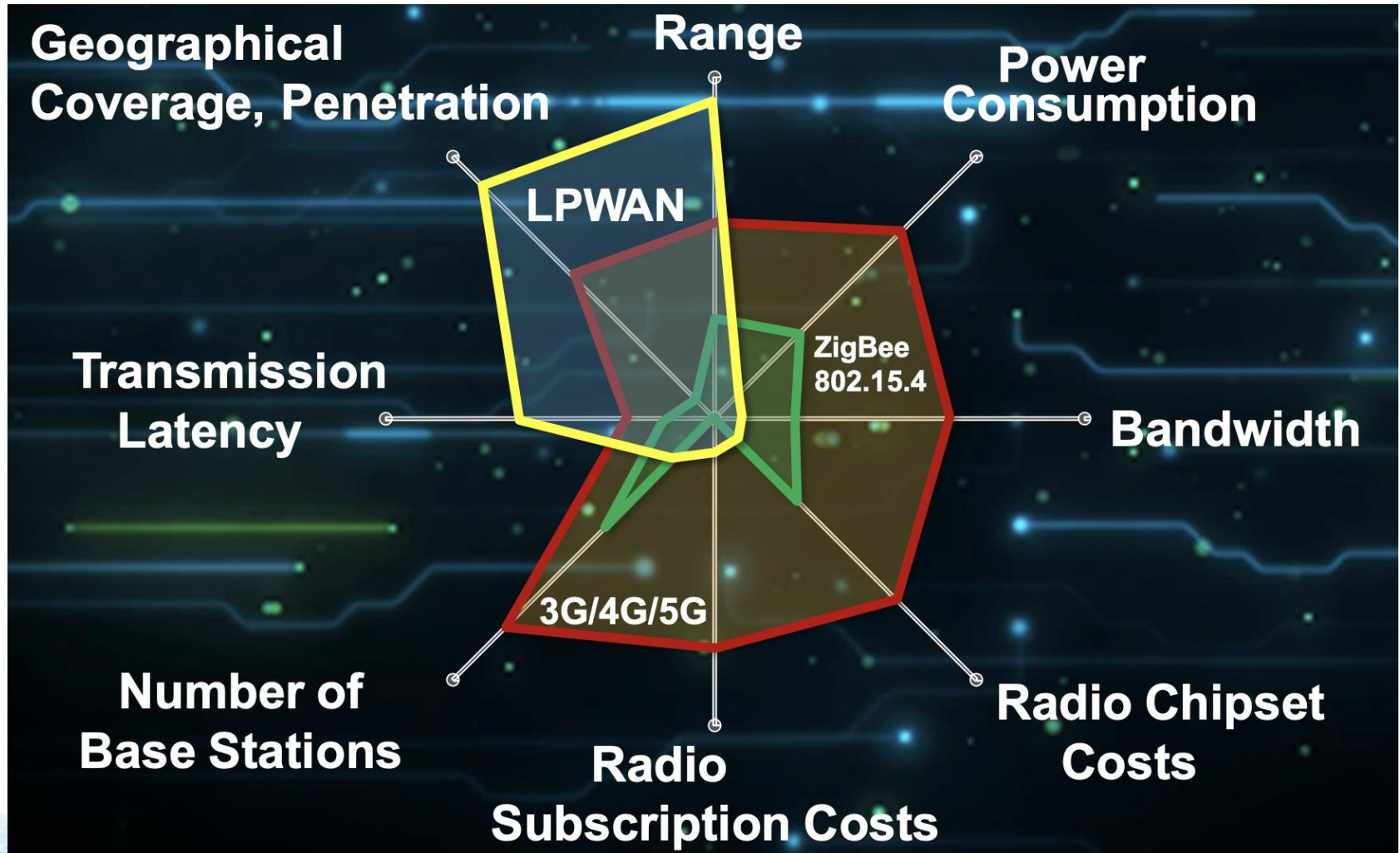



# LPWAN Topology (1/2)

- Direct device connectivity (base station)

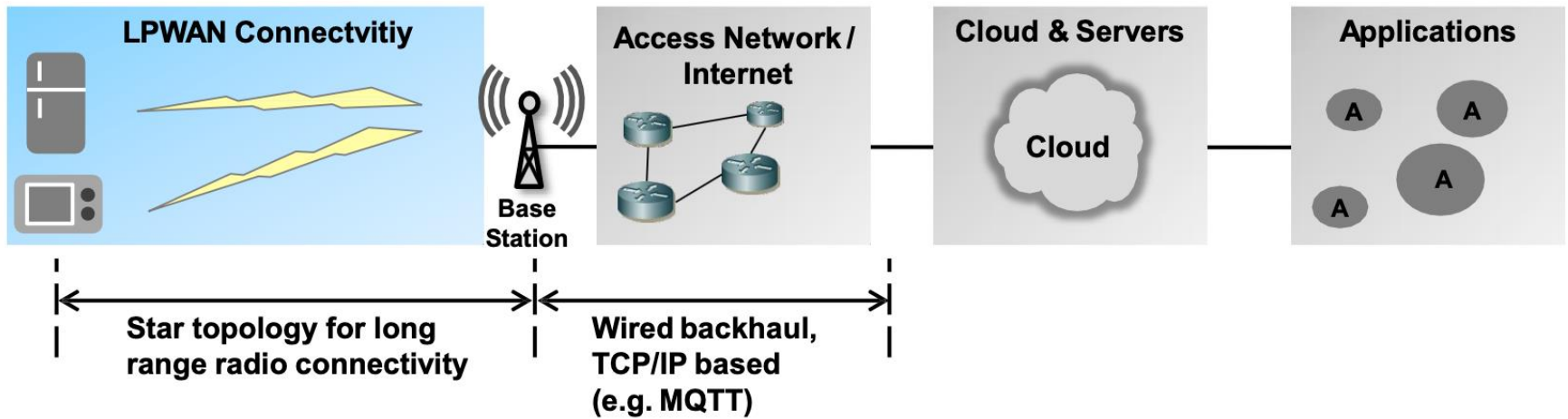

# LPWAN Topology (1/2)

- Indirect device connectivity (through gateway)

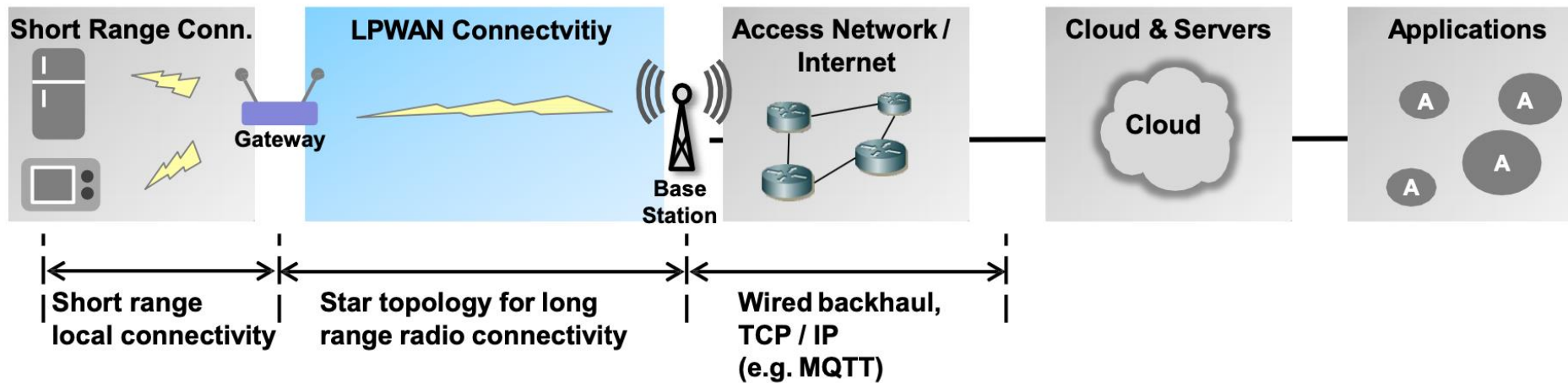



# Important Factors in LPWAN

- The most critical factors in a LPWAN are:
  - Network architecture
  - Communication range
  - Battery lifetime or low power
  - Robustness to interference
  - Network capacity (maximum number of nodes in a network)
  - Network security
  - One-way vs two-way communication
  - Variety of applications served

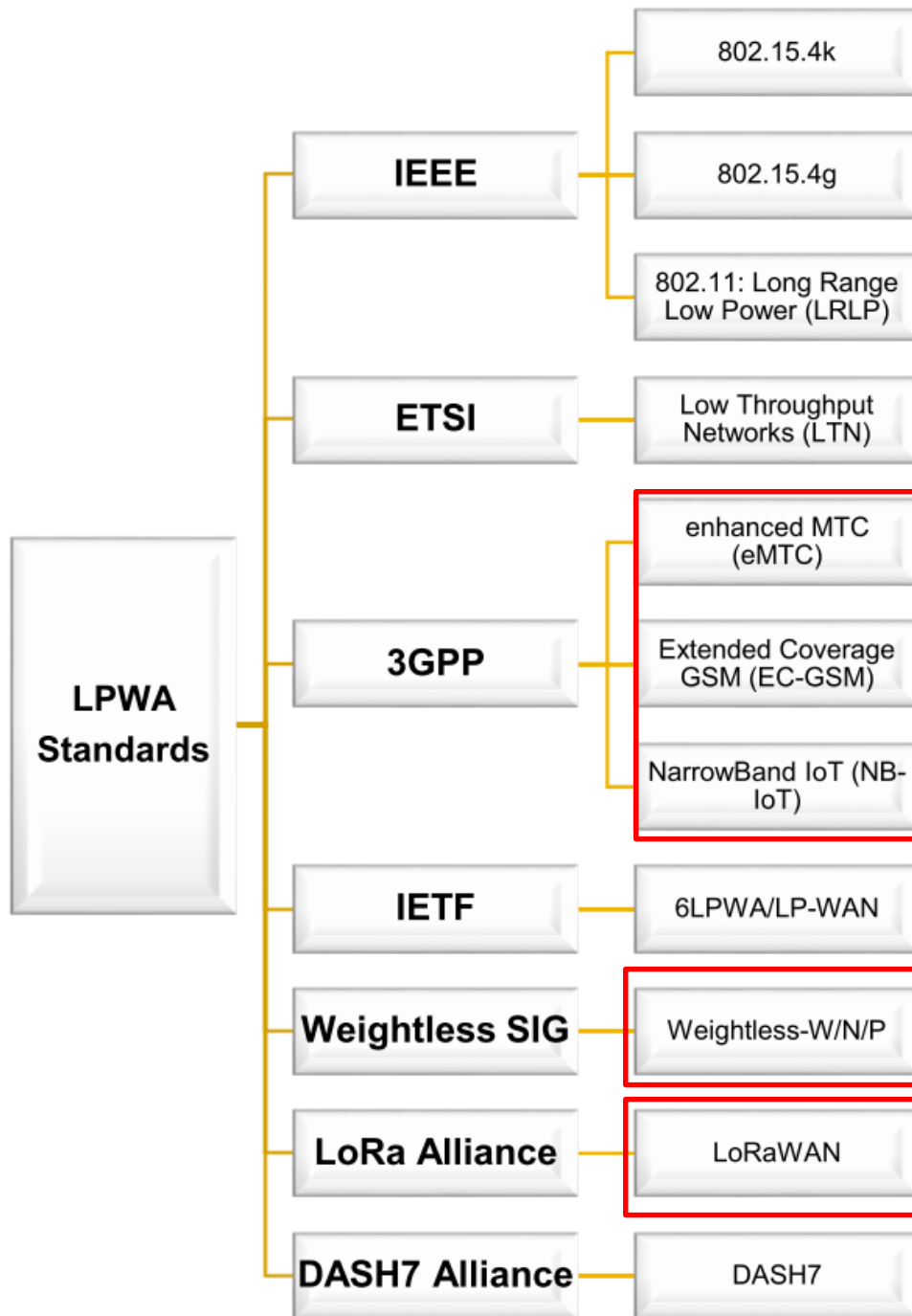



# 3GPP LPWAN

# 3GPP IoT Standardization

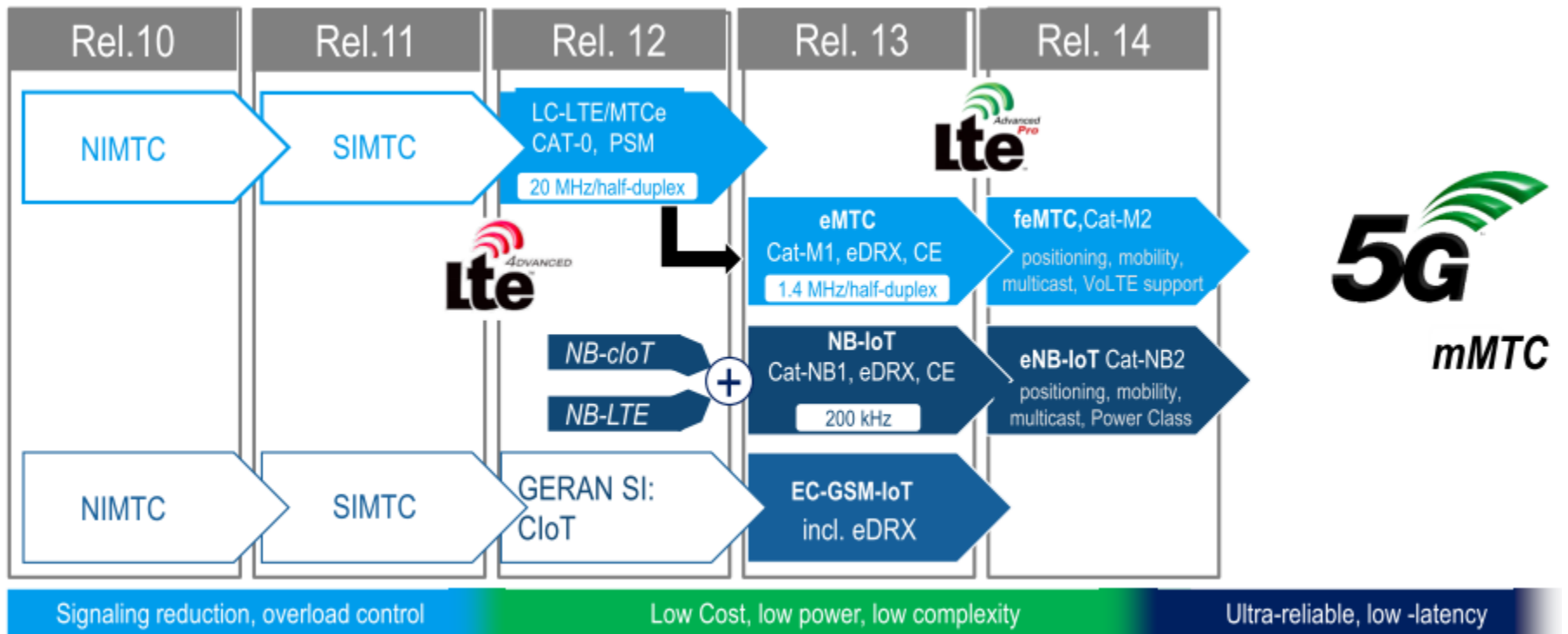

# 3GPP IoT Technical Specifications

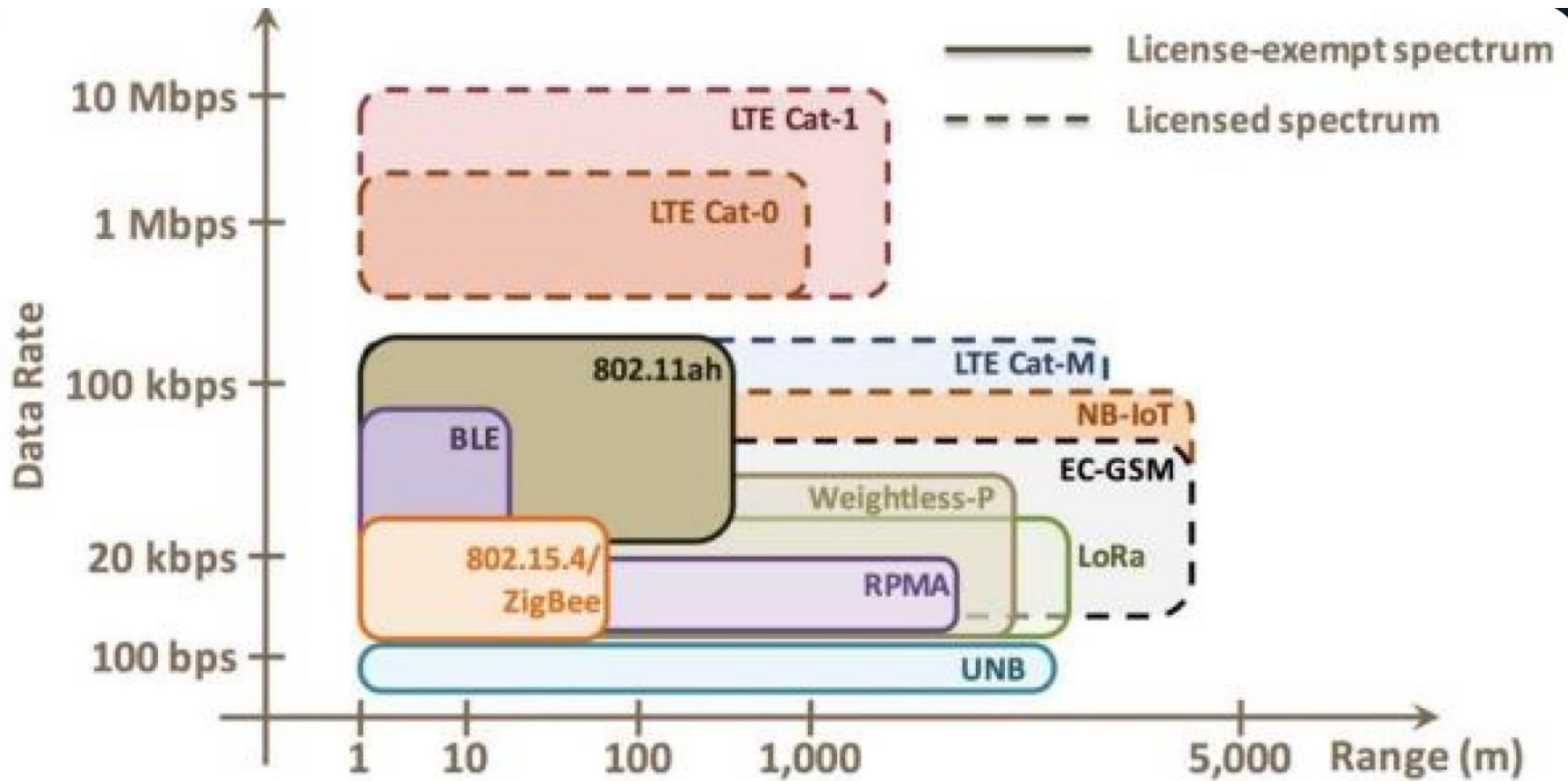

Reproduced with kind permission. © 2016 Mobile Experts LLC. All Rights Reserved.



# 3GPP IoT Technical Specifications

	LTE Cat 0	LTE Cat M1	LTE Cat M2	LTE Cat NB1	LTE Cat NB2
Deployment	In-band LTE	In-band LTE		In-band LTE ; Guard-band LTE Standalone	
Downlink	OFDMA [15 kHz]	OFDMA [15 kHz]		OFDMA [15 kHz]	
Uplink	SC-FDMA[15 kHz]	SC-FDMA [15 kHz]		Single-tone [15/3.75 kHz] SC-FDMA [15 kHz]	
Peak rate	DL: 10 Mbps UL: 5 Mbps	DL: 1 Mbps UL: 1 Mbps	DL: 4 Mbps UL: 4 Mbps	DL: 250 kbps UL: 20 kbps (ST)	
Duplex Mode	Full-duplex FDD/TDD	Full/Half-duplex FDD/TDD		Half-duplex FDD	
UE receiver BW	20 MHz	1.4 MHz	5 MHz	200 kHz	
UE TX power	23 dBm	23 or 20 dBm		23/20 dBm	23/20/14 dBm
Power saving	PSM/eDRX	PSM, eDRX		PSM, eDRX	
Antenna(s)	1 Rx/Tx	1 Rx/Tx		1Tx, 1 or 2 Rx (diversity)	

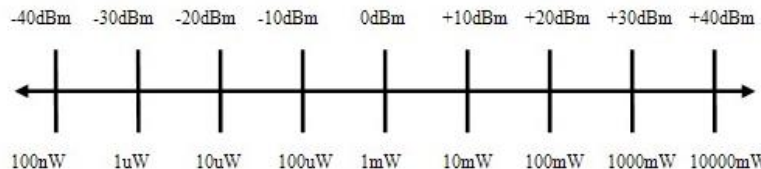

20dbm = 100mW

14dbm = 25mW



# NB-IoT

2016

R13: NB-IoT

-180 kboth Hz UE RF bandwidth for downlink and uplink

3GPP TSG RAN Meeting #72  
RP-161324  
Busan, Korea, June, 2016

2016  
JUN

2017

R14: Enhance NB-IoT (NB-IoTenh)

- Positioning (OTDOA)
- Multicast
- Non-Anchor PRB enhancements
- Mobility and service continuity enhancements
- New low power class

2017  
MAR

R15 WID:  
3GPP TSG RAN-1 88bis  
Further NB-IoT enhancement  
RP-170852  
Spokane, USA, April 2017

2018

R15: Further Enhancement NB-IoT (NB-IoTfenh)

2018  
JUN

5G  
mMTC

The Rel-15 further enhancements to NB-IoT WI was approved at RAN#75, with core part completion due by **June 2018 (RAN#80)**, and the RAN4 performance part by **December 2018 (RAN#82)**.

NB-IoT will evolve toward 5G mMTC

# NB-IoT

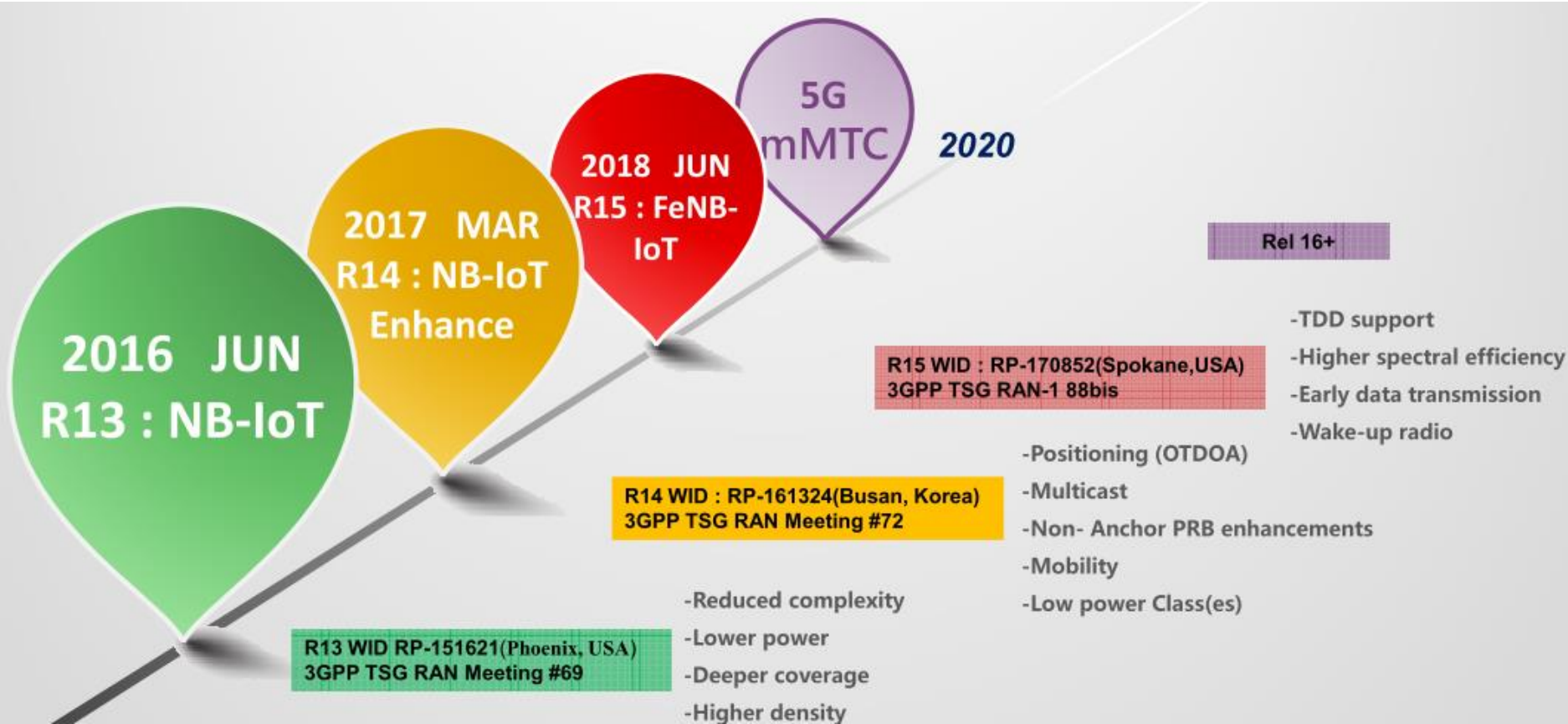



# Comparison among eMTC, NB-IoT and EC-GSM-IoT

	eMTC (LTE Cat M1)	NB-IOT	EC-GSM-IoT
Deployment	In-band LTE	In-band & Guard-band LTE, standalone	In-band GSM
Coverage*	155.7 dB	164 dB for standalone, FFS others	164 dB, with 33dBm power class 154 dB, with 23dBm power class
Downlink	OFDMA, 15 KHz tone spacing, Turbo Code, 16 QAM, 1 Rx	OFDMA, 15 KHz tone spacing, TBCC, 1 Rx Tail Biting Convolutional Coding	TDMA/FDMA, GMSK and 8PSK (optional), 1 Rx
Uplink	SC-FDMA, 15 KHz tone spacing Turbo code, 16 QAM	Single tone, 15 KHz and 3.75 KHz spacing SC-FDMA, 15 KHz tone spacing, Turbo code	TDMA/FDMA, GMSK and 8PSK (optional)
Bandwidth	1.08 MHz	180 KHz	200kHz per channel. Typical system bandwidth of 2.4MHz [smaller bandwidth down to 600 kHz being studied within Rel-13]
Peak rate (DL/UL)	1 Mbps for DL and UL	DL: ~250 kbps UL: ~250 for multi-tone, ~20 kbps for single tone	For DL and UL (using 4 timeslots): ~70 kbps (GMSK), ~240kbps (8PSK)
Duplexing	FD & HD (type B), FDD & TDD	HD (type B), FDD	HD, FDD
Power saving	PSM, ext. I-DRX, C-DRX	PSM, ext. I-DRX, C-DRX	PSM, ext. I-DRX
Power class	23 dBm, 20 dBm	23 dBm, others TBD	33 dBm, 23 dBm

\* In terms of MCL target. Targets for different technologies are based on somewhat different link budget assumptions (see TR 36.888/45.820 for more information).

# EC-GSM-IoT

## Objectives



### Long Battery Life

Run with 5Wh battery for about 10 years  
(depending on flow mode and coverage)



### Equipment Costs are lower compared to GPRS/GSM



### Variable Data Rate

GMSK : ~350bps to 70kbps  
8PSK : up to 240kbps



### Support Large number of devices

About 50,000 devices per unit



### Improve security for IoT constraints



### Shorter time to market and lower costs due to the mature use of GSM/GPRS

## Extended coverage:

164 dB MCL for 33 dBmUE

154 dB MCL for 23 dBmUE

Source: 3GPP



# EC-GSM Technology Introduction

- GSM (Global System for Mobile Communications)
  - The most widely used mobile phone standard.
  - Due to the widespread use of GSM, international roaming which is used by mobile phone operators to sign "**roaming agreements**" is also commonplace.



# EC-GSM Technology Introduction

- The difference between GSM and the old communication system is that its **signaling and voice channels are digital**, so GSM is considered a **second-generation (2G) mobile phone system**.
- The GSM standard is developed and maintained by the 3GPP organization.



# EC-GSM Technology Introduction

- EC-GSM (Extended Coverage GSM)
  - One of LPWAN Technologies
  - EC represents **extended coverage**
  - EC-GSM is the **IoT optimized GSM network**
  - EC-GSM-IoT is to adapt and **leverage existing 2G/3G/4G infrastructure** to provide efficient and reliable IoT connectivity through extended GSM coverage.

# EC-GSM Technology Introduction

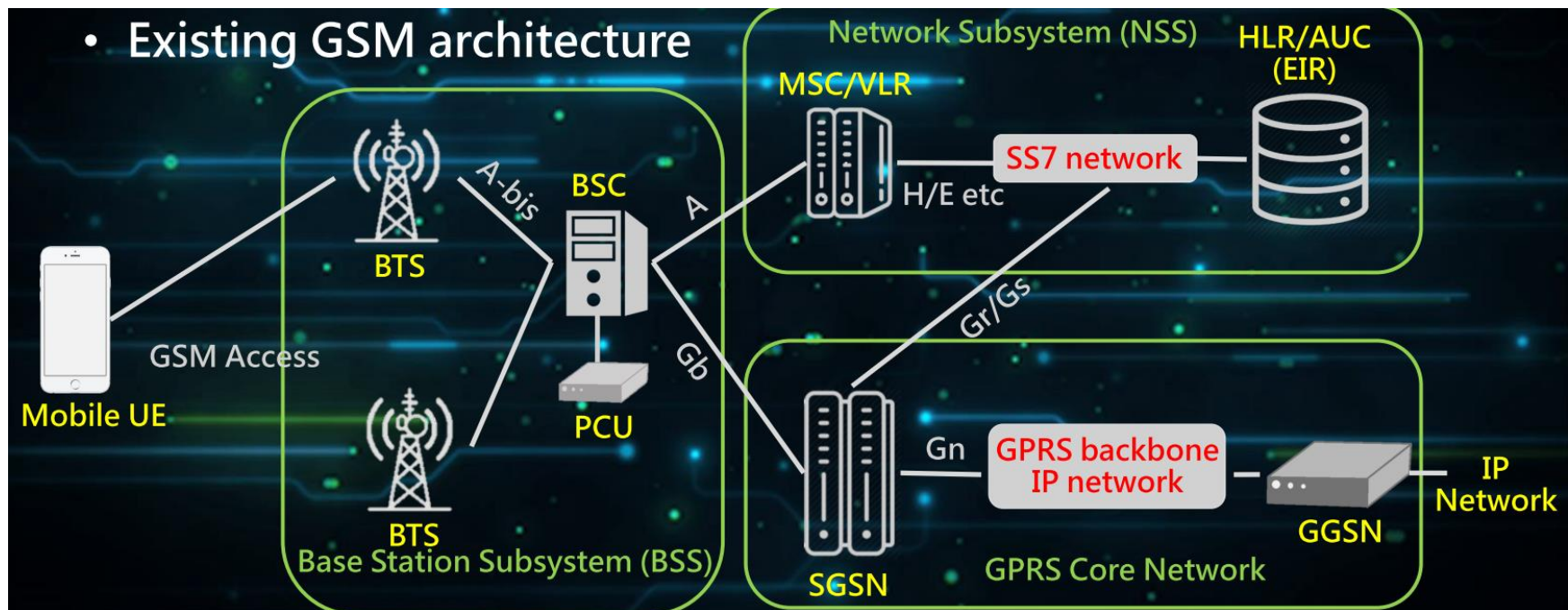



# EC-GSM Technology Introduction

## • EC-GSM architecture

EC-GSM	
Frequency Band	NarrowBand
Range	~ 15 Km
Throughput	~ 10 Kbps

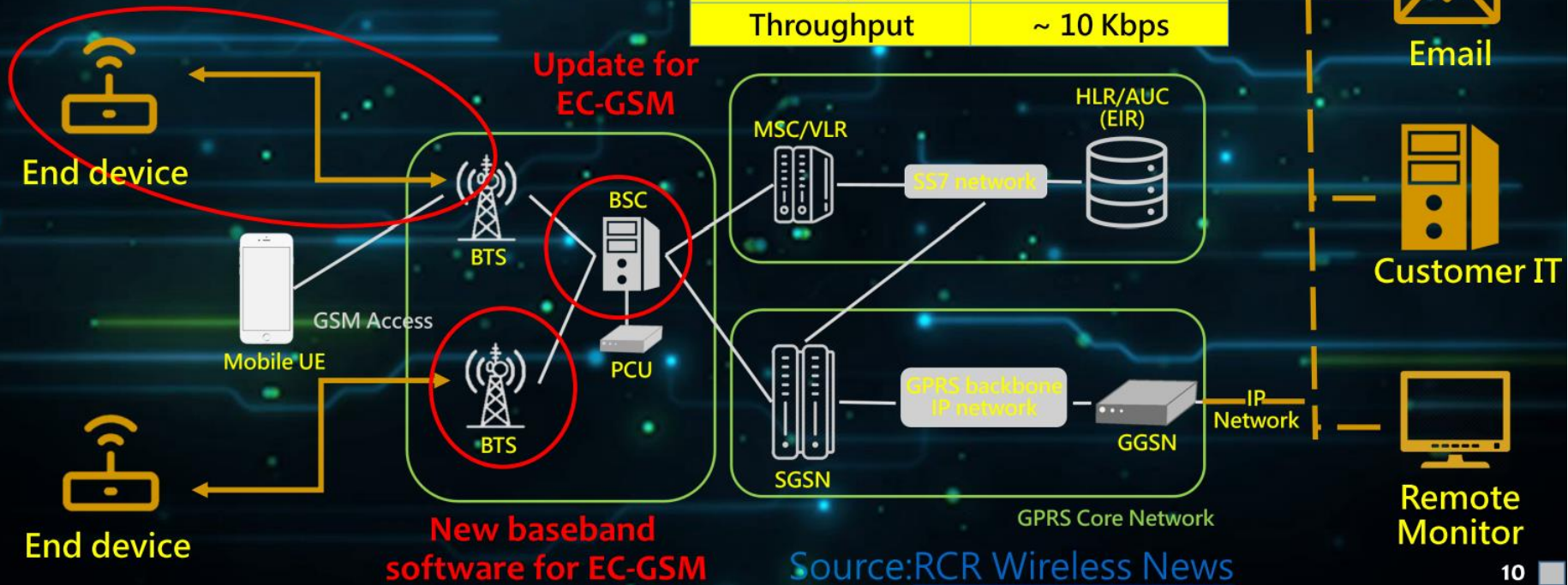



# EC-GSM-IoT (Cont.)

- **Main PHY Features**

- New logical channels designed for extended coverage Repetitions to provide necessary robustness to support up to 164 dB MCL
- Overlaid CDMA to increase cell capacity (used for EC-PDTCH and EC-PACCH)

- **Other Features**

- Extended DRX (up to ~52min)
- Optimized system information (i.e. no inter-RAT support)
- Relaxed idle mode behavior (e.g. reduced monitoring of neighbor cells)
- 2G security enhancements (integrity protection, mutual authentication, mandate stronger ciphering algorithms)
- NAS timer extensions to cater for very low data rate in extended coverage
- Storing and usage of coverage level in SGSN to avoid unnecessary repetitions over the air

Source: 3GPP

# LTE-M

- A study for low-cost LTE is on-going in 3GPP since September 2011. Release 12 has specified LTE Cat0 (LTE-M) and Release 13 evolves to eMTC.

3GPP Release	8 (Cat. 4)	8 (Cat. 1)	12 (Cat.0) LTE-M	13 (Cat.1,1.4 MHz) LTE-M
Downlink peak rate (Mbps)	150	10	1	1
Uplink peak rate (Mbps)	50	5	1	1
Number of antennas (MIMO)	2	2	1	1
Duplex Mode	Full	Full	Half	Half
UE Receive Bandwidth (MHz)	20	20	20	1.4
UE Transmit Power (dBm)	23	23	23	20

Source: 3GPP

# MOBILE IoT GLOBAL COVERAGE

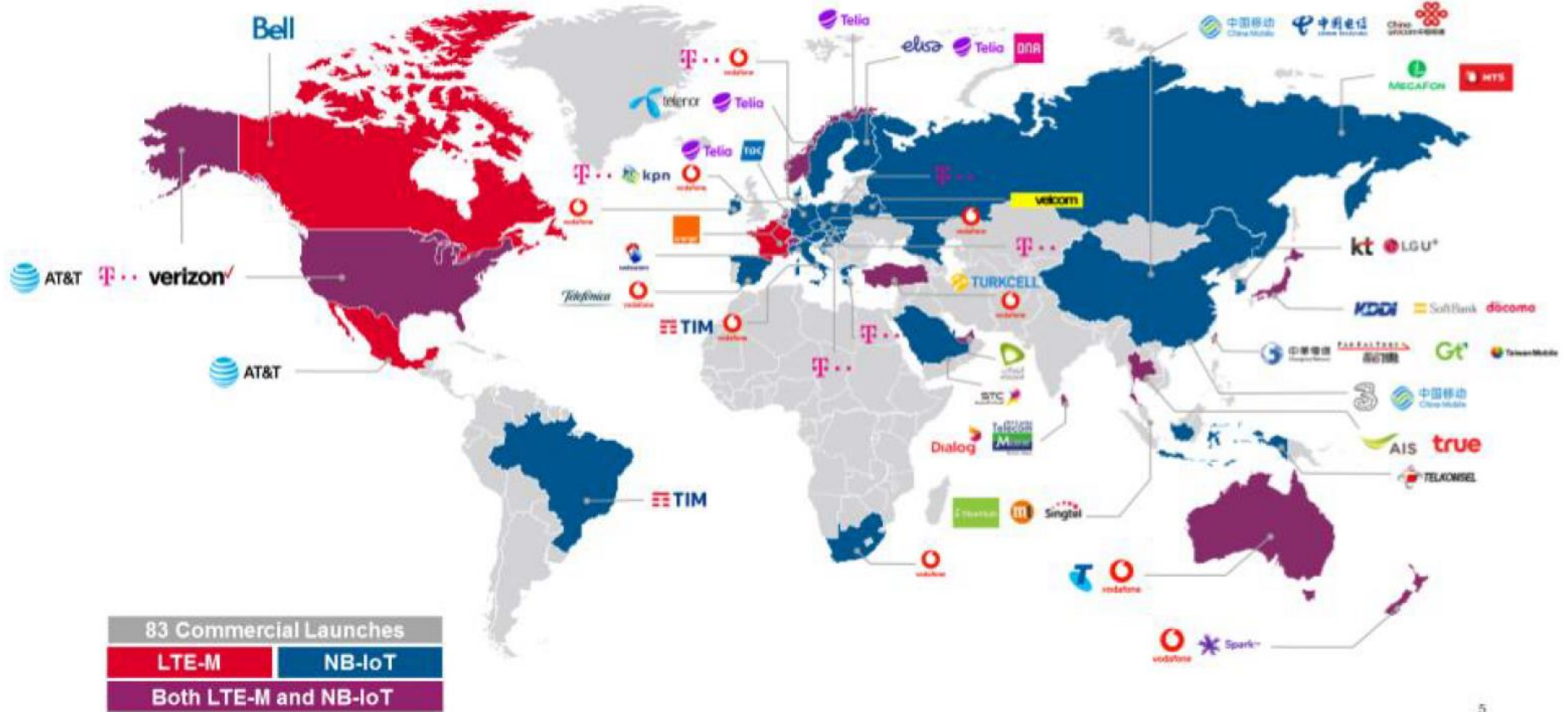



# LTE-M

- Main goal of the study is to reduce cost of LTE devices to be utilized for M2M.

Identified approaches include:

- Reduction of Bandwidth
- Hardware simplification
- Reduction of Transmit Power
- Reduction of Peak Rate

Source: 3GPP

# LTE-M



## High Transfer Rate

The LTE-M terminal supports a larger bandwidth, 5 times the peak rate of NB-IoT uplink/ downlink.



## Throughput < 1Mbps



## Support mobility

Supports base station handover



## Low Latency < 100ms



## Easy to deploy



# LTE-M for 3GPP Rel. 12

- Antennas
  - Only 1 receive antenna compared to 2 antennas for other device categories
- Transport block size
  - Send or receive up to **1000 bits** of unicast data per sub-frame
  - Reduce the max data rate to **1 Mbps** in both the uplink and the downlink
- Duplex
  - Half duplex FDD devices are supported as an optional feature

Source: 3GPP

# LTE-M for 3GPP Rel. 12

- Existing LTE architecture

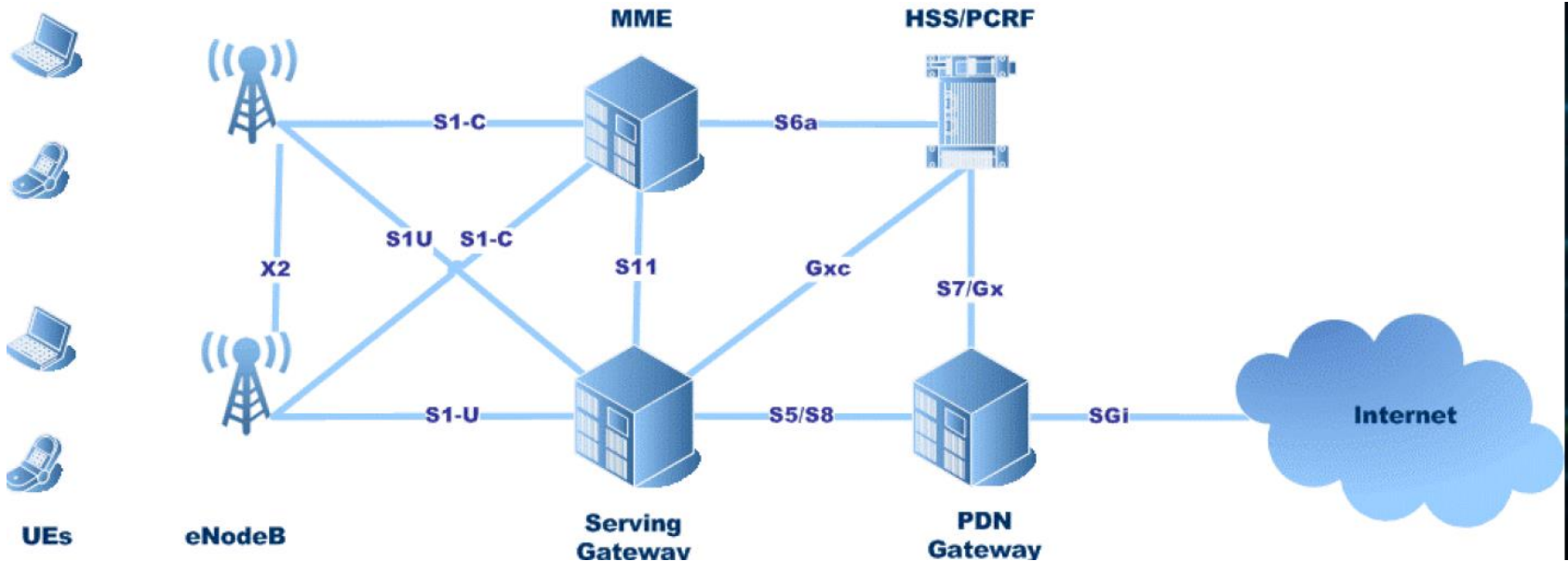

Source: 3GPP



# LTE-M for 3GPP Rel. 12

## • LTE-M architecture

LTE-M	
Frequency Band	NarrowBand
Range	~ 11 Km
Throughput	~ 1 Mbps

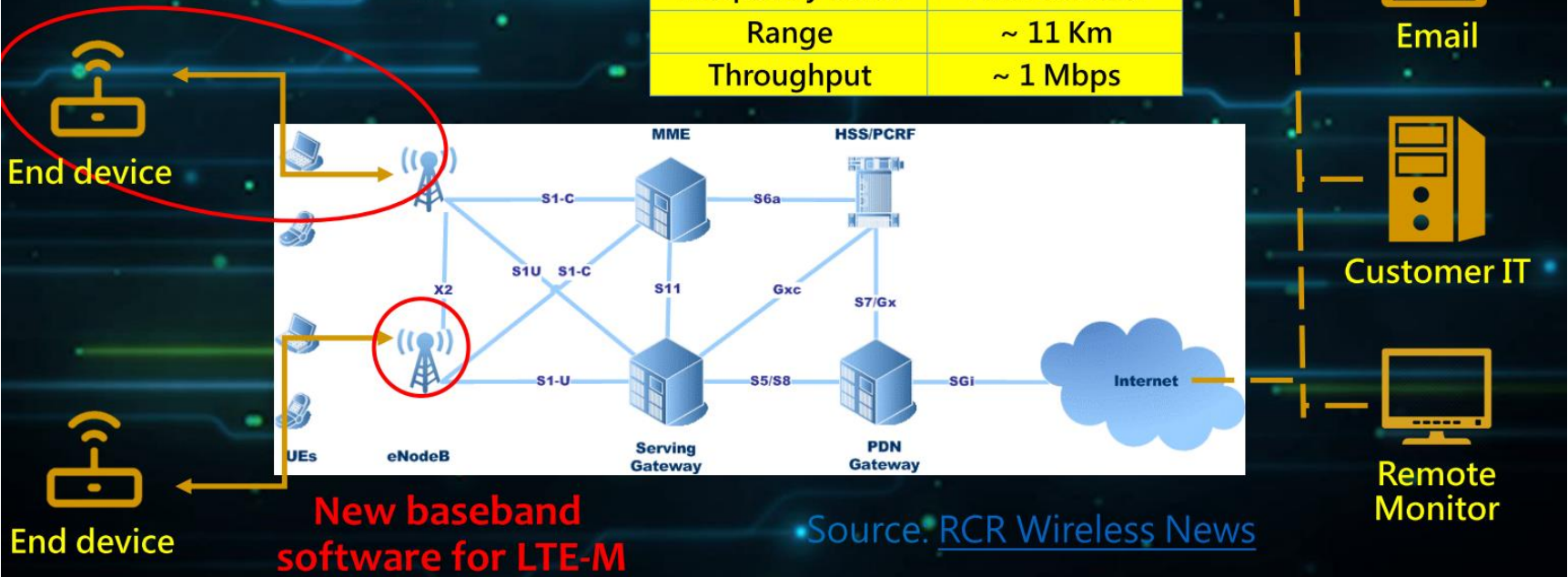

Source: 3GPP



# eMTC for 3GPP Rel. 13

## Objectives

- Long battery life: ~10 years of operation with 5 Watt Hour battery
- Low device cost: comparable to that of GPRS/GSM devices
- Extended coverage: >155.7 dB maximum coupling loss (MCL)
- Variable rates: ~10 kbps to 1 Mbps depending on coverage needs

## Deployment

- Can be deployed in any LTE spectrum
- Coexist with other LTE services within the same bandwidth
- Support FDD, TDD and half duplex (HD) modes
- **Reuse existing LTE base stations** with software update
- Coverage can reach 11km.



# eMTC for 3GPP Rel. 13 (Cont.)

## Main PHY/RF Features

- **Narrowband operation with 1.08 MHz bandwidth (6 RBs)**
- Frequency hopping with narrowband retuning for frequency diversity
- TTI bundling/repetition to achieve large coverage enhancements
- New UE power class of 20 dBm
- Further cost reduction beyond Cat 0 (no wideband control channel, reduced TM support, reduced HARQ)

Source: 3GPP



# NB-IoT

## NB-IoT GLOBAL COVERAGE

NB-IoT = 60								
Operator	Market	Bands	Operator	Market	Bands	Operator	Market	Bands
3	HONG KONG	8	ETISALAT	UAE	3	TAIWAN MOBILE	TAIWAN	3, 28
AIS	THAILAND	8	FAREASTONE	TAIWAIN	28	TELEFONICA	SPAIN	20
APTG	TAIWAIN	8	KT	SOUTH KOREA	8	TELENOR	NORWAY	20, 8
CHINA MOBILE	CHINA	8	LGU+	SOUTH KOREA	12	TIM	ITALY	20
CHINA MOBILE	HONG KONG	3	M1	SINGAPORE	20,8	TIM	BRAZIL	3, 28
CHINA TELECOM	CHINA	5	MOBITEL	SRI LANKA	8	TURKCELL	TURKEY	20
CHINA UNICOM	CHINA	8	MEGAFON	RUSSIA	20,8,3	TRUE	THAILAND	8
CHUNGHWA	TAIWAIN	8	MTS	RUSSIA	3	TELKOMSEL	IDONESIA	8
DIALOG	SRI LANKA	3, 8	ORANGE	BELGUIM	20	VELCOM	BELARUS	8
DNA	FINLAND		SINGTEL	SINGAPORE		VODAFONE	AUSTRALIA	8
DT	AUSTRIA	8	SOFTBANK	JAPAN		VODAFONE	CZECH REPUBLIC	20
DT	CROATIA	20, 8	STC	SAUDI ARABIA	12	VODAFONE	GERMANY	20
<b>DT</b>	<b>HUNGARY</b>	<b>20</b>	SWISSCOM	SWITZERLAND	20	VODAFONE	IRELAND	20
DT	GERMANY	20	<b>STARHUB</b>	<b>SINGAPORE</b>	<b>8</b>	VODAFONE	ITALY	20
DT	GREECE	20	TDC	DENMARK	20	VODAFONE	SPAIN	20
DT	POLAND	20	TELIA	FINLAND	20, 3	VODAFONE	THE NETHERLANDS	20
DT	SLOVAKIA	20	TELIA	NORWAY	20	VODAFONE	TURKEY	20
DT	THE NETHERLANDS	20	TELIA	SWEDEN	20	VODAFONE	SOUTH AFRICA	8
T-Mobile US	US	2, 4, 12	TELIA	DENMARK	20, 8	VODAFONE	MALTA	20
ELISA	FINLAND	20, 3	TELSTRA	AUSTRALIA	28	<b>VODAFONE</b>	<b>NEW ZEALAND</b>	<b>28</b>

# NB-IoT

## Objectives

- Even lower cost than eMTC
- Extended coverage: **164 dB** maximum coupling loss
- Long battery life: 10 years with 5 Watt Hour battery
- **Support for massive number of devices: ~50,000 per cell**

## Main simplification

- Reduced data rate/bandwidth, mobility support and further protocol optimizations

## NB-IoT supports 3 modes of operation:

- **Stand-alone:** utilizing stand-alone carrier, e.g. spectrum currently used by GERAN systems as a replacement of one or more GSM carriers
- **Guard band:** utilizing the unused resource blocks within a LTE carrier's guard-band
- **In-band:** utilizing resource blocks within a normal LTE carrier

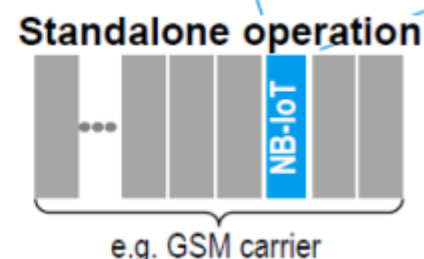
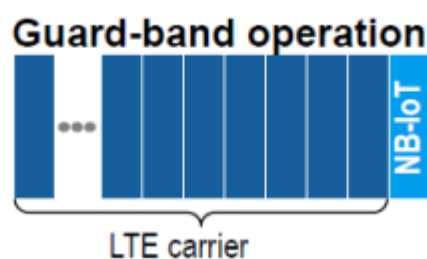
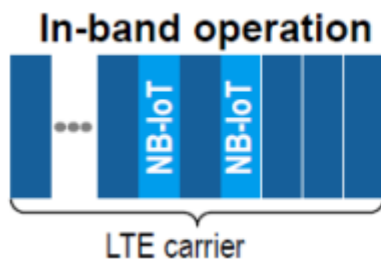

Source: 3GPP

# Technology Attributes

- In-band, Guard band, Standalone (GSM)
- 180KHz bandwidth = 1 PRB (12x15KHz)
- Half duplex FDD
- Downlink (DL)
  - OFDMA , 15 kHz subcarrier spacing,
  - All numerology identical to LTE
  - Slot, subframe, and frame durations: 0.5 ms, 1 ms, and 10 ms
  - Modulation: QPSK
- Uplink (UL)
  - (F1) SC-FDMA/ST @15 kHz spacing; (F2) ST @ 3.75 kHz spacing

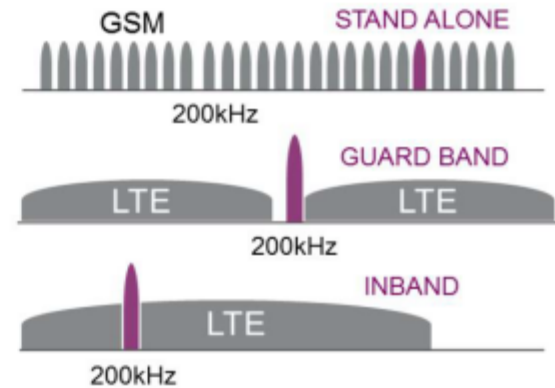

Uplink	Numerology	Multi-tone	Single-tone
15 KHz Subcarrier Spacing	Identical to LTE	√	QPSK
3.75 KHz Subcarrier Spacing	Slot : 2ms	N/A	$\pi/2$ -BPSK or $\pi/4$ -QPSK



# Technology Attributes

項目	NB-IoT 技術規格
Standard	• 3GPP <b>R14.2</b> (3-2017)
Duplex	• Half Duplex FDD (Type B) · BW 200kHz
Frequency Bands	• Band 3、5、7、8 (900)、20 (800)、28 (700), 其它可調 (450MHz 至 2.1GHz 全频段)
Mode	• <b>Stand-alone</b>
RF	• Tx power: <b>23dBm (1T2R)</b>
Data Rate	• DL : 27.2 kbps, UL: 62.5 kbps (R13)
Cell Size	• < <b>2 km</b> (NPRACH format 0)
Low Power	• Support PSM and eDRX for 10+ year battery
Massive Connections	• Up to <b>52547</b> devices for up to 588526 UL reports per day (TR-45.820) • Concurrent #devices: 64 (TBD) 
Backhaul	• S1-lite interface
Low Cost	• Platform <b>BOM cost &lt; \$100</b> (Q1-2018)

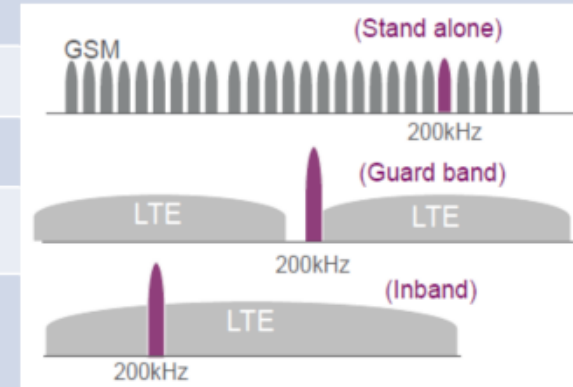



# NB-IoT 14 working bandwidth (Rel-13)

頻段編號	上行頻率範圍/MHz	下行頻率範圍/MHz
Band1	1920~1980	2110~2170
Band2	1850~1910	1930~1990
Band3	1710~1785	1805~1880
Band5	824~849	869~894
Band8	880~915	925~960
Band12	699~716	729~746
Band13	777~787	746~756
Band17	704~716	734~746
Band18	815~830	860~875
Band19	830~845	875~890
Band20	832~862	791~821
Band26	814~849	859~894
<b>Band28</b>	<b>703~748</b>	<b>758~803</b>
Band66	1710~1780	2110~2200

180 kHz for each carrier

台灣大哥大

中華電信  
亞太電信

遠傳電信



# NB-IoT Key Features

**Optimised power consumption**



> 10 year battery Life

**High propagation:  
Better coverage**



+ 20 db link budget  
(vs. GSM)

**High end-point density**



> 100,000 connections  
per cell

**Low complexity devices**



Targeting modules  
Costing just a few \$

**Limited throughput**



< 200 kbps

**Bi-directional communication**



Uplink and downlink  
capability

**LTE Level security**



Encryption, SIM based  
authentication

**Global standard in  
Licensed spectrum**



Uplink and downlink  
capability

# NB-IoT Key Features



## High Coverage

Strong indoor coverage and **20dB gain over LTE** equivalent to 100 times coverage area.



## High Connectivity

One sector can support 50-100K connections.



## Low Power Consumption

NB-IoT uses PSM and eDRX technology for up to several years of standby time.



## Low Cost



## High Security

# NB-IoT architecture

## • NB-IoT architecture

NB-IoT	
Frequency Band	Ultra Narrow Band
Range	~ 11 Km
Throughput	~ 150 Kbps

End device

End device

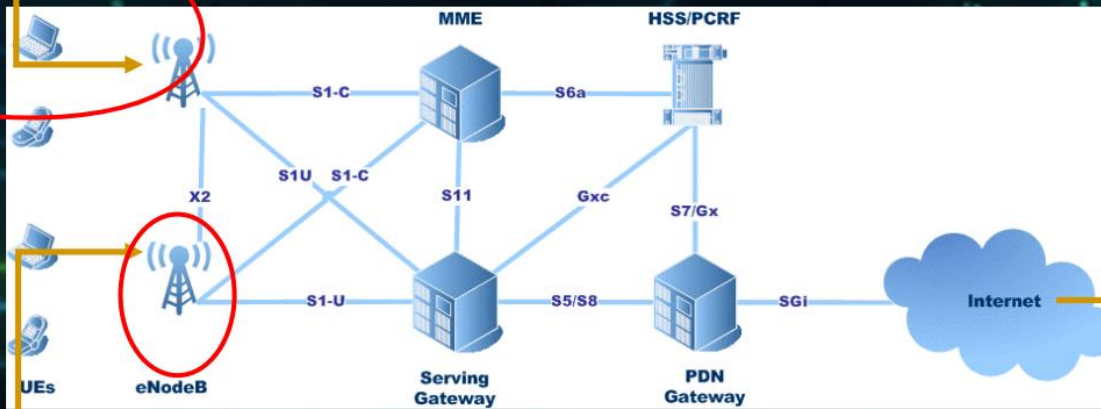

**New baseband software for NB-IoT**



Email



Customer IT



Remote Monitor

Source: RCR Wireless News



# LTE-M to NB-IoT

3GPP Release	12 (Cat. 0) LTE-M	13 (Cat. 1,1.4 MHz) LTE-M	13 (Cat. 200KHz) NB-IoT
Downlink peak rate	1 Mbps	1 Mbps	300 bps to 200 kbps
Uplink peak rate	1 Mbps	1 Mbps	144 kbps
Number of antennas (MIMO)	1	1	1
Duplex Mode	Half	Half	Half
UE Receive Bandwidth	20 MHz	1.4 MHz	200 kHz
UE Transmit Power (dBm)	23	20	23

# NB-IoT

## Main PHY features

- Narrow band support of **180 kHz**
- Supports two modes for uplink
  - Single tone with 15 kHz and/or 3.75 kHz tone spacing
  - Multiple tone transmissions with 15 kHz tone spacing ( **$12 \times 15 = 180$** )
- No support of Turbo code for the downlink
- Single transmission mode of SFBC (Space Frequency Block Coding) for PBCH, PDSCH, PDCCH
- New narrowband channels:
  - NPSS, NSSS, NPBCH, NPDCCH, NPDSCH, NPUSCH, NPRACH

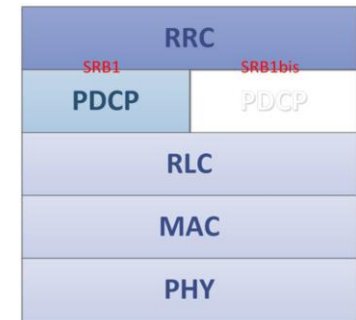

# Resource Block

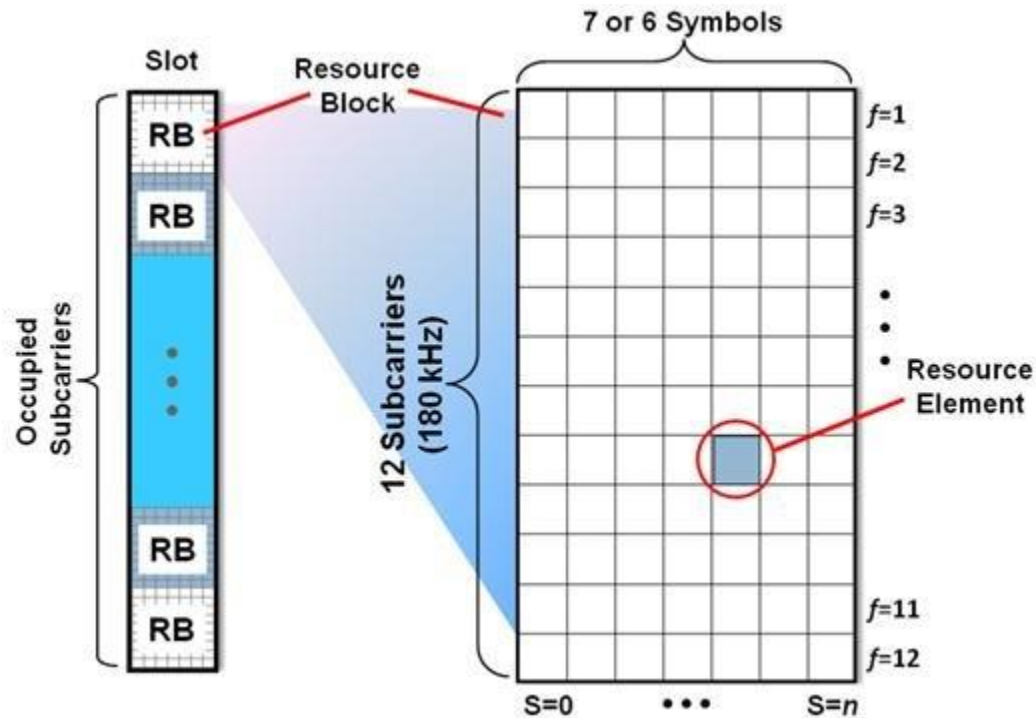

# Frame

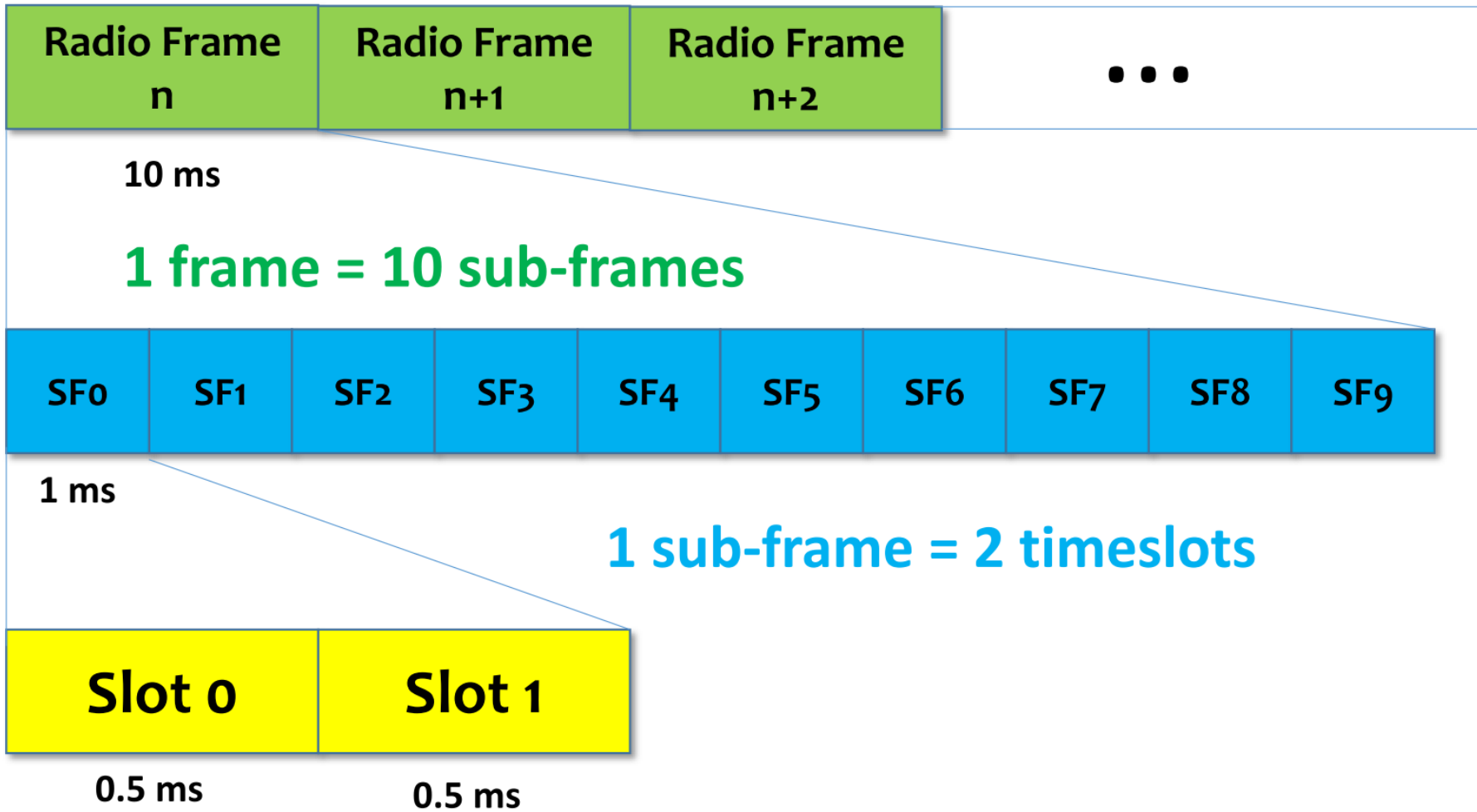



# NB-IoT (Cont.)

## Main radio protocol Features

- Single HARQ process
- Only RLC AM mode with simplified status reporting
- Two PDCP options:
  - SRB 0 and 1 only. No AS security (NAS security is used instead). PDCP operating in transparent mode.
  - SRB 0, 1, 2 and one DRB. AS security, which is cached upon RRC connection release.
- For PDCP option 2, RRC connection suspend/resume procedures to maintain AS security context.
- Significantly reduced broadcast system information

Source: 3GPP



# SBO, 1, 2

系統資訊名稱		簡介
MasterInformationBlock	SB0	帶有最重要且接收其他訊息前必須的資訊，如phich-Config、systemFrameNumber等
SystemInformationBlocks1	SB1	包含有關UE是否被允許進入該cell以及定義其他系統資訊區塊排程等資訊
SystemInformationBlocks2	SB2	包含了該cell下常用且共享的通道資訊，如無線資源組態等

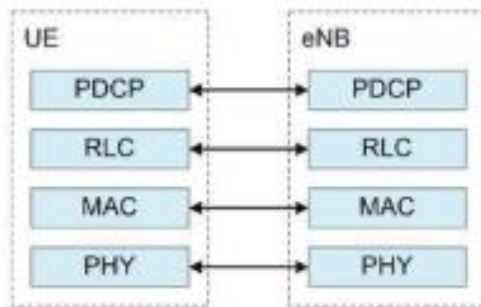

User Plane

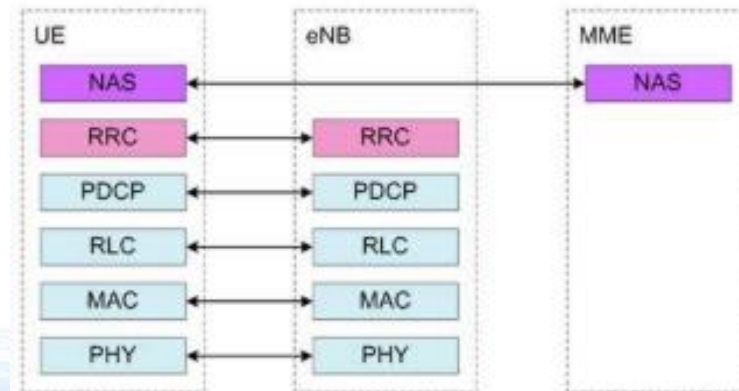



# 3GPP R14(Enhance NB-IoT, eNB-IoT)

- 執行Anchor載波的訊務卸載 (Non- Anchor PRB enhancements)
- 增強窄頻物聯網使用裝置之移動性(Mobility)
- 調降最大傳輸功率等級(Low power Class(es))
  - 14dBm (最低訊號(MCL)需提高到164 dB)
- 引進單細胞中點對多點傳輸技術(Single Cell-Point to MultiPoint, SC-PTM)
- 定位功能 (Positioning, OTDOA)
- 物聯網設備(UE)密度可達每平方公里100萬個

Source: 3GPP



# R15

- TDD support
- Higher spectral efficiency
- Early data transmission
- Wake-up radio

Source: 3GPP



# NB-IoT “Cell Access”

- NB-IoT UE needs to establish connection with base station first (same as LTE UE)
  1. Search signal from default channel to **get System Information Base (SIB)** from base station.
  2. Issue **Random Access** signal to establish a connection (RRC connection) with base station.
  3. Receive or transmit data.



# R14 NB-IoT Connection Establishment

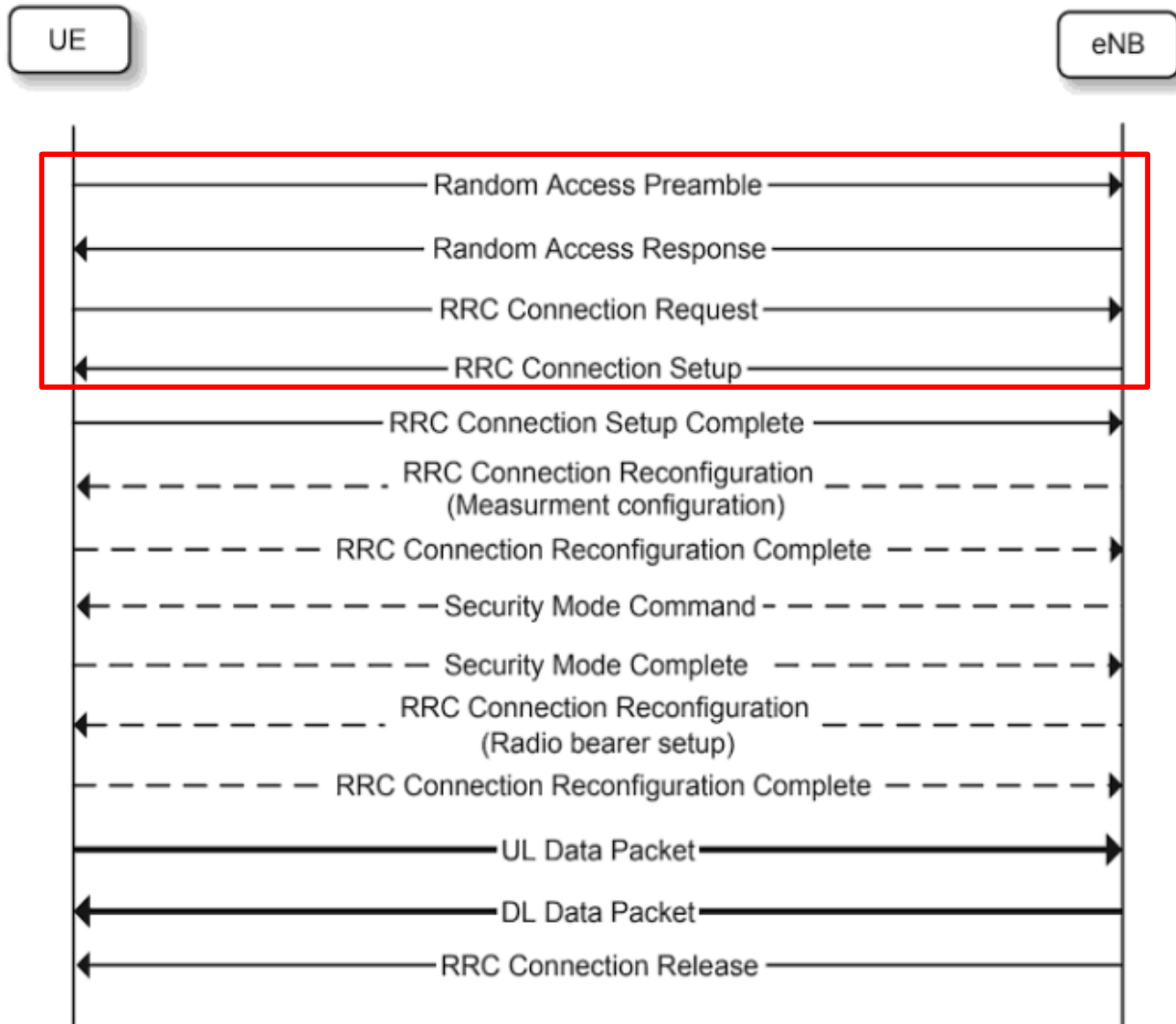

# RACH Procedure

- 程序一: 初始同步與讀取系統資訊

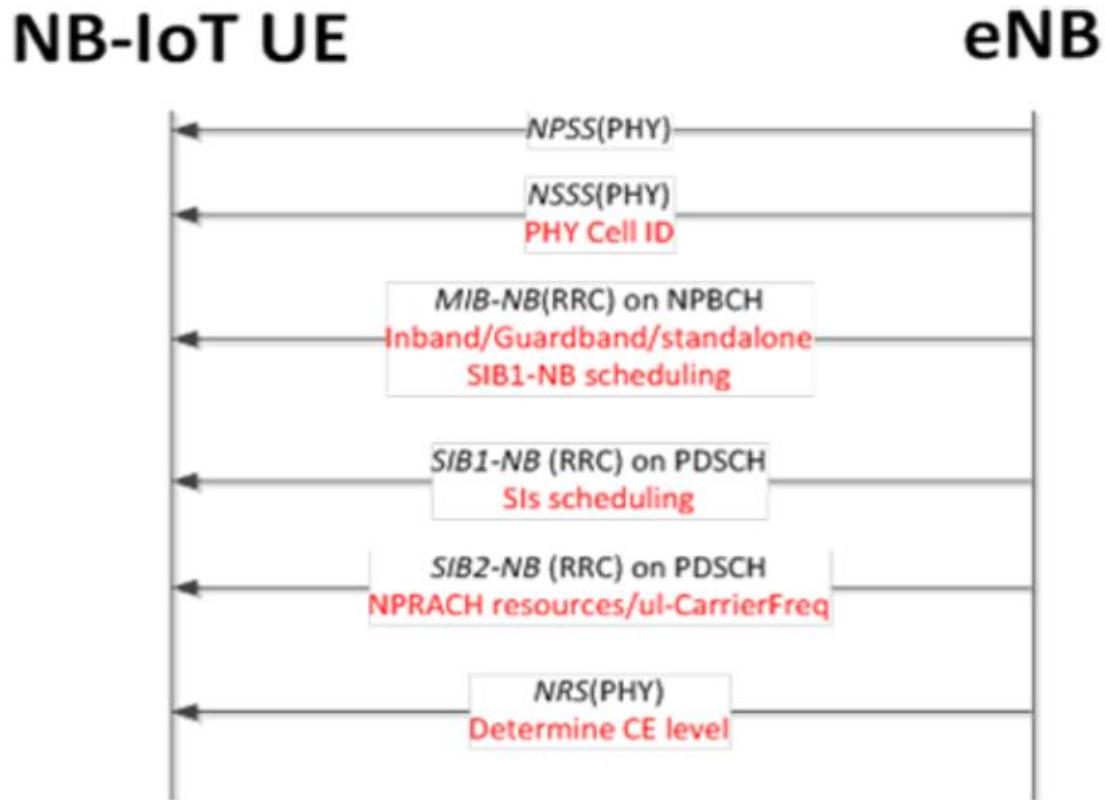

# 連線過程

- 程序一:初始同步與讀取系統資訊
  - UE先讀取eNB於Anchor載波上所廣播的NB-IoT專屬的 Narrow Band Primary Synchronization Signal (NPSS)與 Narrow Band Secondary Synchronization Signal (NSSS)，以完成同步。並解出Physical Cell ID。
  - 接著，UE讀取eNB於Anchor載波上所廣播的NB-IoT Master Information Block-Narrow Band (MIB-NB)與 System Information Block-Narrow Band (SIB-NB)。這些資料可被重複傳送，故傳送之週期被延長為640毫秒與2560毫秒。其中，NB-IoTMIB-NB是被連續傳輸在每個訊框(Frame)中的第0號Sub-frame，該資訊區塊內會指示該載波的運行模式(頻段內(In-band)、保護頻段(Guard band)以及獨立(Stand-alone)共三種運行模式)與NB-IoT專屬第一系統資訊區塊(SIB1-NB)之部份排程資訊(Scheduling Information)。

# 連線過程

- 程序一:初始同步與讀取系統資訊
  - NB-IoT **SIB1-NB** 排程資訊會進一步包含其餘NB-IoT SIB2-NB~SIB16-NB的排程資訊。
  - NB-IoT使用者裝置必須先讀取到**NB-IoT SIB2-NB** 中的Narrow Band Physical Random Access Channel (**NPRACH**)資源配置資訊，方能進行後續之隨機存取程序。
  - 此外，該NB-IoT SIB2-NB也同時包含了對應於Anchor載波的上行載波頻段配置資訊。



# 連線過程

- 連線過程(程序二:隨機存取程序)

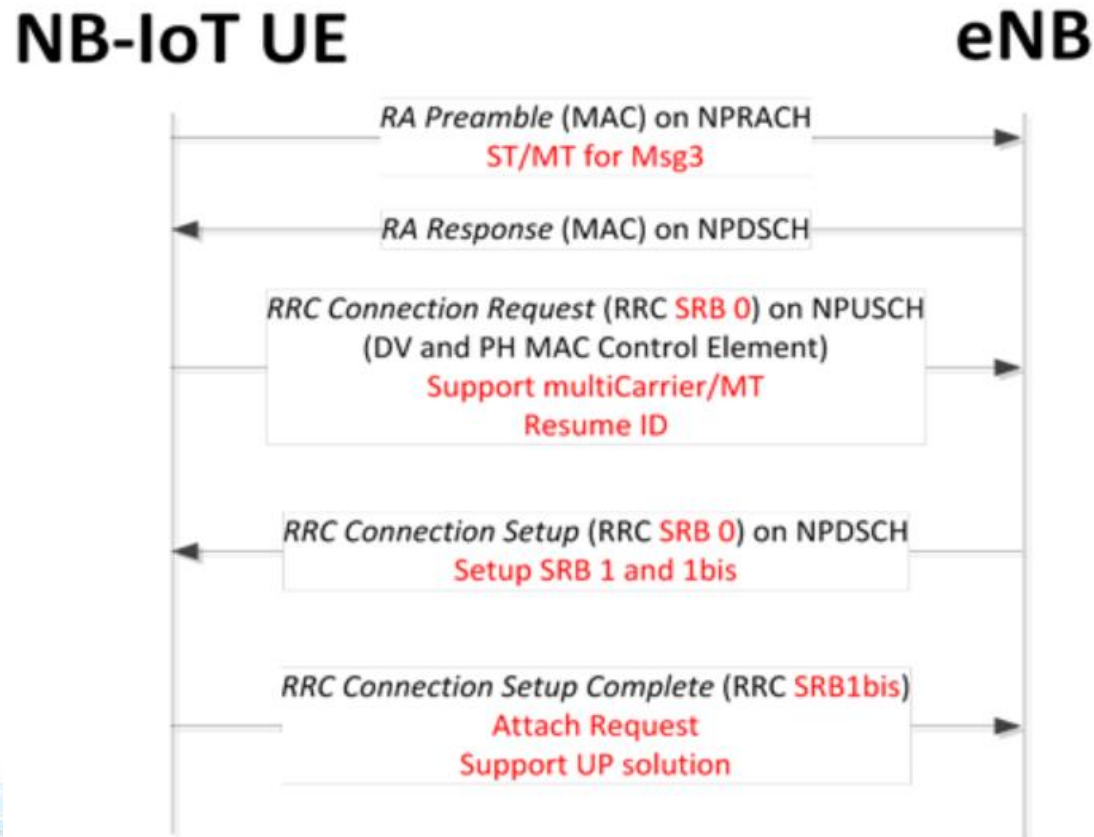

# 連線過程

- 連線過程(程序二:隨機存取程序)
  - NB-IoT UE在獲取到隨機存取必要資源配置資訊後，即可以在窄頻物理隨機存取通道上進行隨機存取程序。
  - NB-IoT UE在進行隨機存取程序之前，須先決策自己的涵蓋範圍延伸等級(CE Level)。該等級的決策是NB-IoT使用者裝置自行藉由量測下行參考訊號接收功率(Reference Signal Receive Power, RSRP)，並參考NB-IoT SIB2-NB中的參考訊號接收功率臨界來決定。

# 連線過程

- 連線過程(程序二:隨機存取程序)
  - 窄頻物理隨機存取通道的資源配置共包含了以下幾種重要資訊：通道出現之週期、通道於頻率軸上的位置、通道於時間軸上的位置、通道使用之子載波數量、Preamble最大重試次數與Preamble每次傳送重複次數等。
  - NB-IoT UE根據自己第三道訊息傳輸是支援單頻或多頻傳輸，於對應的子載波上傳送Preamble。
  - NB-IoT 仍保有非競爭式(Contention Free)的隨機存取資源。

# 連線過程

- 連線過程(程序二:隨機存取程序)
  - 原LTE中，UE上行資料傳輸所需的資源取得 Buffer Status Report (BSR)與Power Headroom Report (PHR)之程序。當UE完成上述回報程序後，基地台才會根據使用者裝置將暫存器內準備好要傳送的資料量與功率餘裕來做出對應之上行資源配給。
  - NB-IoT 增加了 Data piggyback in NAS message (見後面投影片說明)



# Preamble of NPRACH

- Preamble of NPRACH consists of 4 continuous Preamble Symbol Groups
- For larger coverage, also uses repetition and frequency hopping
- Hopping range: 12, 24, 36, or 48 neighbor sub-carriers
- As long as start sub-carrier is different, then the following hopping will not have sub-carrier conflict

# Preamble Repetition and Hopping

**Preamble = 4 Preamble Symbol Groups**

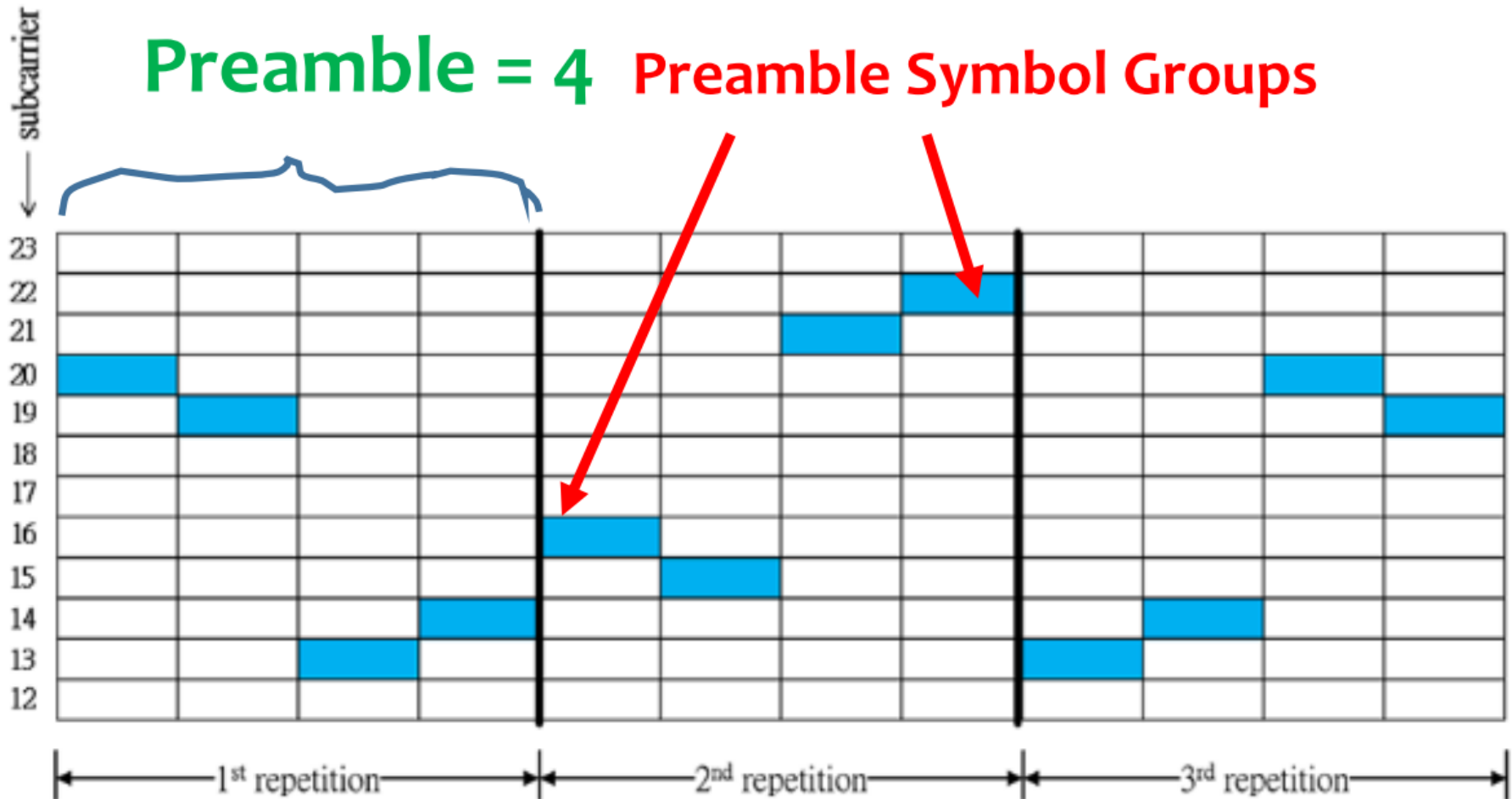

# CE0, CE1, CE2 NPRACH

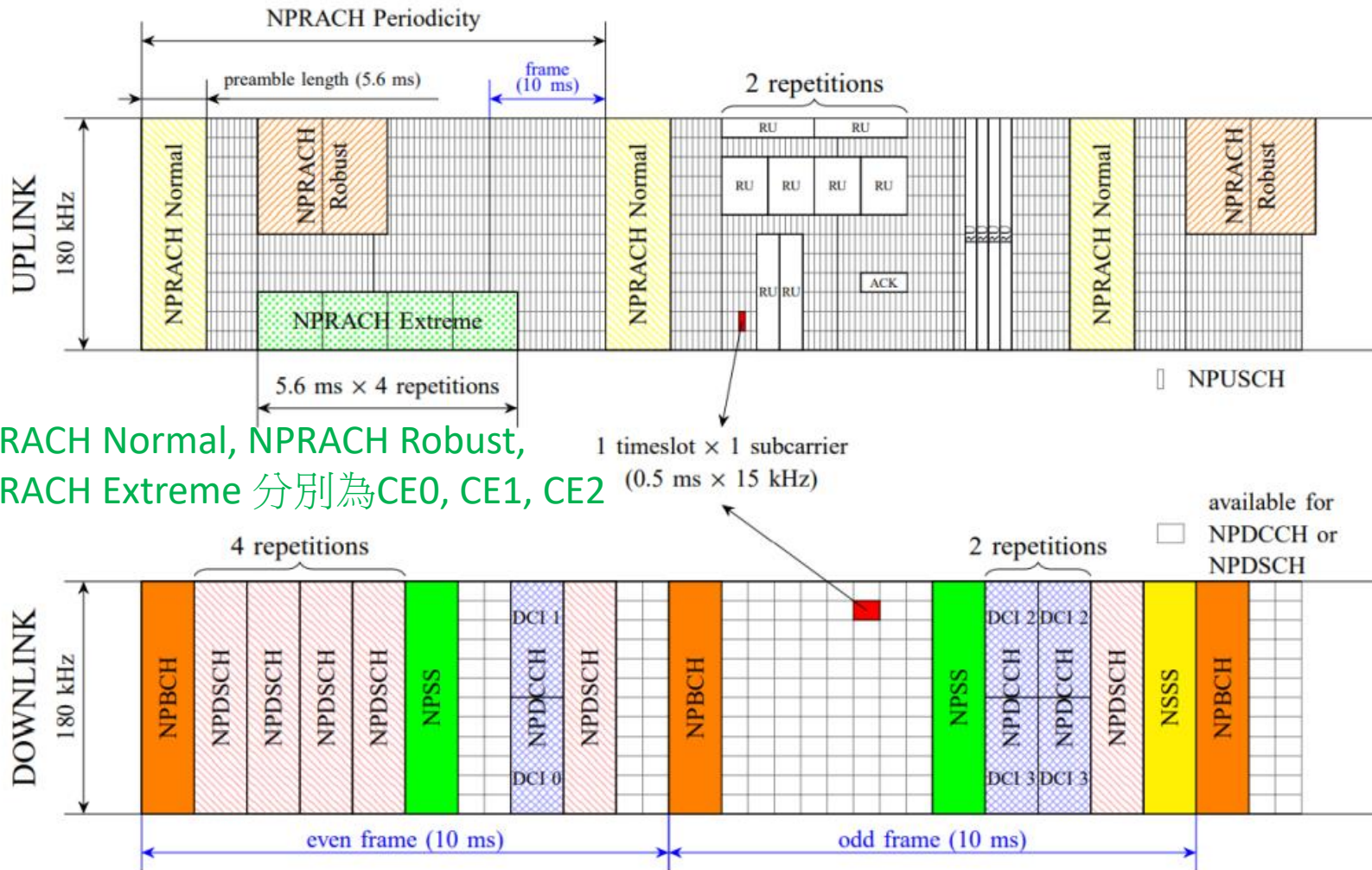

NPRACH Normal, NPRACH Robust, NPRACH Extreme 分別為CE0, CE1, CE2



# Require Physical Channels or Signals

Process	Require Physical Channels or <b>Signals</b>
Receive SIB from base station	Narrowband Physical Broadcast Channel (NPBCH) <b>Narrowband Primary Synchronous Signal (NPSS)</b> <b>Narrowband Secondary Synchronous Signal (NSSS)</b> <b>Narrowband Reference Signal (NRS)</b>
Issue Random Access signal, establish RRC connection	<b>Narrowband Physical Random Access Channel (NPRACH)</b> Narrowband Physical Downlink Share Channel (NPDSCH) <b>Narrowband Physical Uplink Share Channel (NPUSCH)</b>
Starts receive data	Narrowband Physical Downlink Control Channel (NPDCCH) <b>De-modulation Reference Signal (DMRS)</b>

Uplink: NPRACH(random access), NPUSCH (data)



# NB-IoT Control Channel

- 每個NB-IoT的subframe在time domain上跨越一個PRB，跨越1ms。

Even numbered frame	Subframe number										10ms
	0	1	2	3	4	5	6	7	8	9	
	NPBCH	NPDCCH or NPDSCH	NPDCCH or NPDSCH	NPDCCH or NPDSCH	NPDCCH or NPDSCH	NPSS	NPDCCH or NPDSCH	NPDCCH or NPDSCH	NPDCCH or NPDSCH	NPDCCH or NPDSCH	NSSS
Odd numbered frame	Subframe number										10ms
	0	1	2	3	4	5	6	7	8	9	
	NPBCH	NPDCCH or NPDSCH	NPDCCH or NPDSCH	NPDCCH or NPDSCH	NPDCCH or NPDSCH	NPSS	NPDCCH or NPDSCH	NPDCCH or NPDSCH	NPDCCH or NPDSCH	NPDCCH or NPDSCH	NPDCCH or NPDSCH



# Downlink Data Transmission

- QPSK signal modulation, support up to 2 antenna ports
- For 2 antenna ports, multiple antenna transmission mode use Space Frequency Block Coding (SFBC)
- These 3 channels use the same antenna ports:
  - Narrowband Physical Broadcast Channel (NPBCH)
  - Narrowband Physical Downlink Share Channel (NPDSCH)
  - Narrowband Physical Downlink Control Channel (NPDCCH)



# NB-IoT Synchronization Signal

- Downlink OFDM signal uses **Cyclic Prefix (CP)** to reduce Inter Symbol Interference (ISI)
- Node needs to know the start of OFDM symbol to remove the CP precisely → **Synchronization**
- NB-IoT Synchronization signal as LTE structure
- **NPSS: Narrowband Primary Synchronization Signal**
- **NSSS: Narrowband Secondary Synchronization Signal**



# NPSS and NSSS

- UE uses NPSS to detect frame boundary
- Sent at 6 th subframe (SF5) of each frame (every 10ms)
- UE uses NSSS to detect subframe boundary and the ID of base station (NcellID) sent these signals
- Sent at 10 th subframe (SF9) of each even frame (every 20ms)

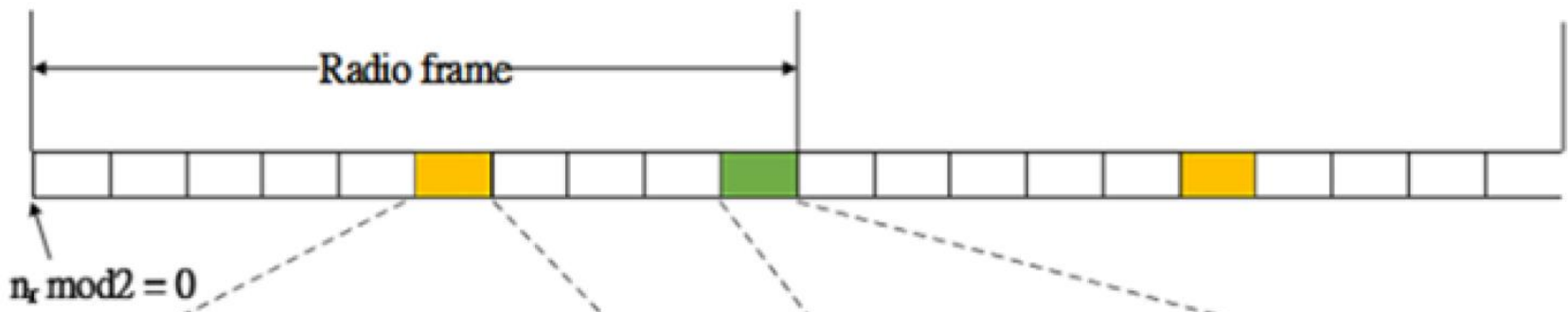

# NPSS and NSSS Signals

- In-band mode, LTE downlink control channel (PDCCH) uses 3 symbols
- LTE also needs CRS resource elements
- CRS puncture on NPSS or NSSS

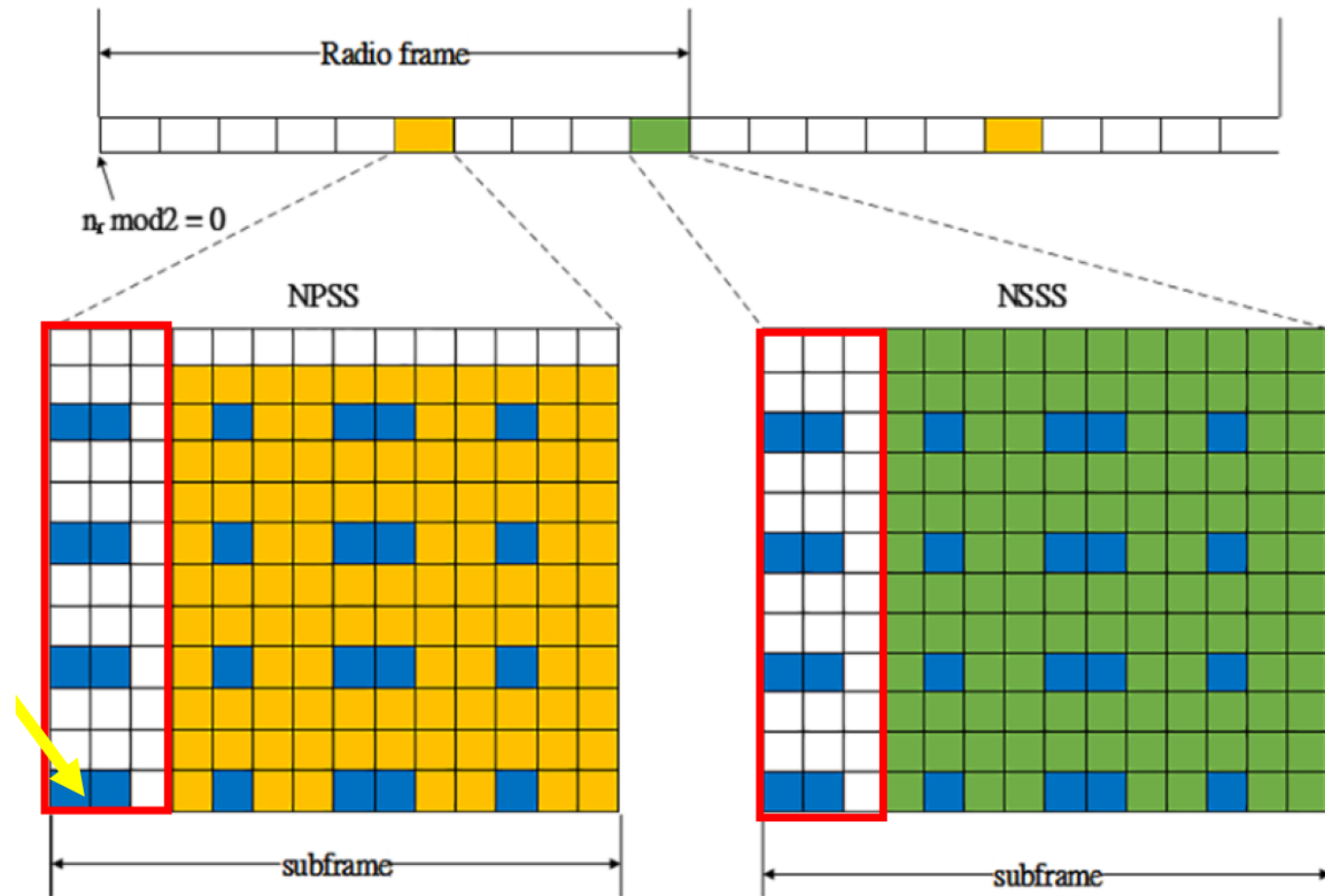

# NRS Signal

- After receives NSSS, UE gets NCellID and all **NRS parameters**
- To **demodulate** signals from each physical channel

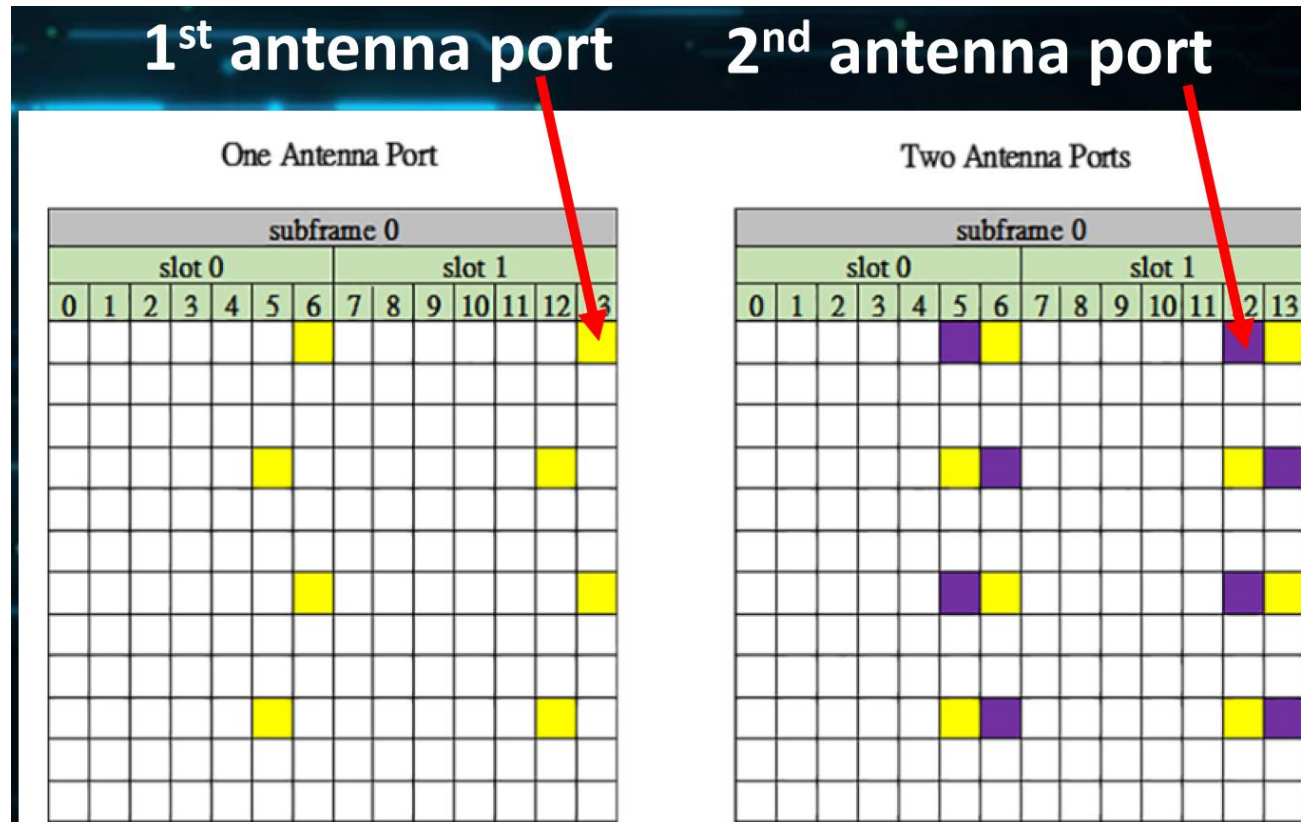



# NPBCH

- Base station uses this channel to send **MIB-NB** (Narrowband Master Information Block), **34 bits**
  - System parameters, System frame number (SFN), superframe number, scheduling, operation mode, etc
- After coding and modulating, **34 bits** generate **800 QPSK symbols**
- Divided into **8 blocks**, each of **100 symbols**
- Each block's mapping

# Block's Mapping (100 symbols)

- Sent at 1<sup>st</sup> subframe of each frame, and repeated after 7 frames
- Each block sent 8 times
- Whole MIB-NB (8 blocks) is partitioned into 64 frames (640 ms)

		subframe 0													
		slot 0							slot 1						
		0	1	2	3	4	5	6	7	8	9	10	11	12	13
PRB	11	Red	Red		12	Red	Purple	Yellow	Red	Red	64	76	Red	Purple	Yellow
	10				11	20	28	36	44	52	63	75	84	92	100
	9				10	19	27	35	43	51	62	74	83	91	99
	8	Red	Red		9	Red	Yellow	Purple	Red	Red	61	73	Red	Yellow	Purple
	7				8	18	26	34	42	50	60	72	82	90	98
	6				7	17	25	33	41	49	59	71	81	89	97
	5	Red	Red		6	Red	Purple	Yellow	Red	Red	58	70	Red	Purple	Yellow
	4				5	16	24	32	40	48	57	69	80	88	96
	3				4	15	23	31	39	47	54	68	79	87	95
	2	Red	Red		3	Red	Yellow	Purple	Red	Red	55	67	Red	Yellow	Purple
	1				2	14	22	30	38	46	54	66	78	86	94
	0				1	13	21	29	37	45	53	65	77	85	93





# MIB-NB Transmission via 64 frames

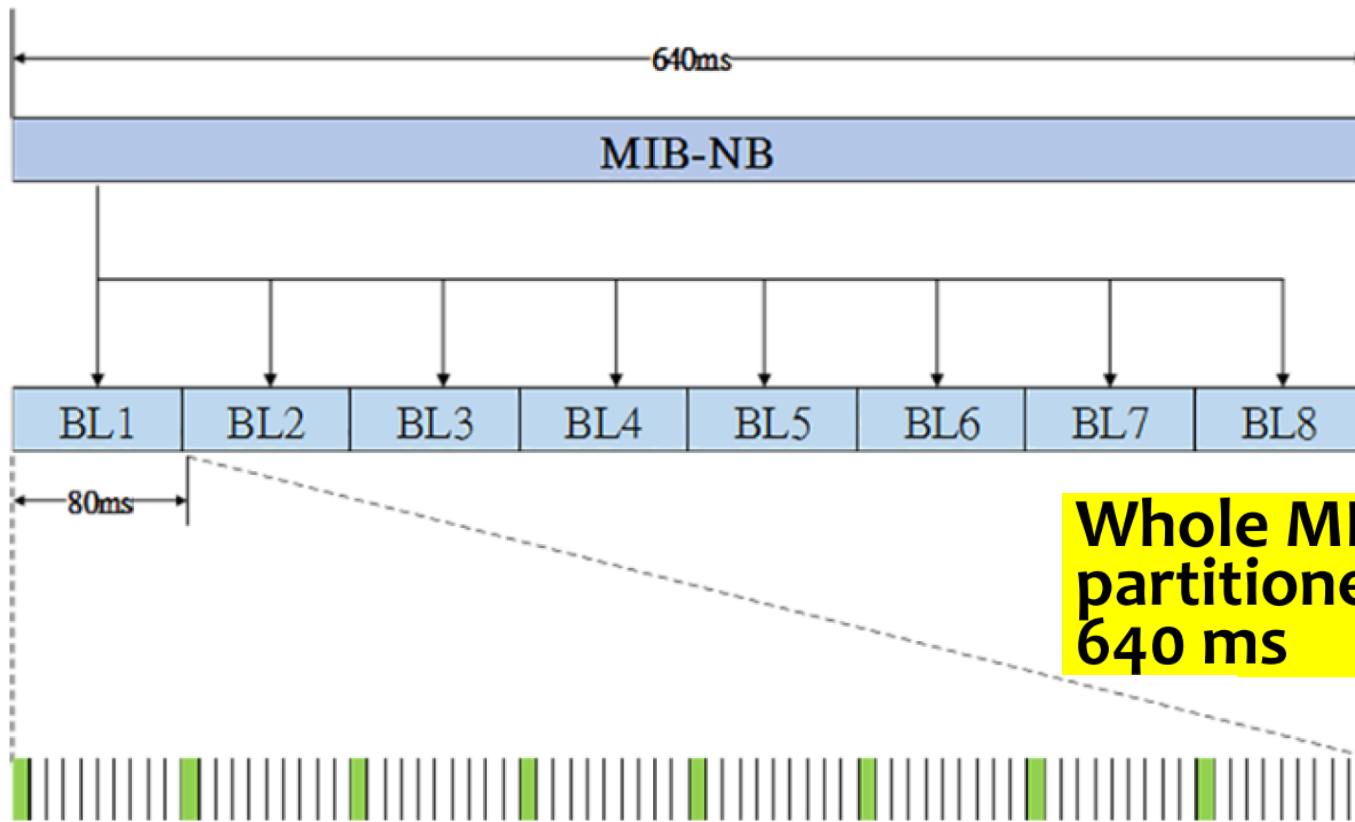

**Whole MIB-NB (8 blocks) is partitioned into 64 frames, 640 ms**



# NPDCCH

- Used to inform UE that data is coming and parameters to receive the data (for example, when)
- Also provides **Uplink grant** to UE (when to transmit)
- **Paging** UE
- Update UE's system information
- Each UE has a **Radio Network Temporary Identifier (RNTI)** to decode the **DCI (Downlink Control Information)**



# NPDCCH's resource elements

- A resource block consists of 2 NCCE (Narrowband Control Channel Element)
- NPDCCH format 0 uses 1 NCCE, format 1 uses 2 NCCE

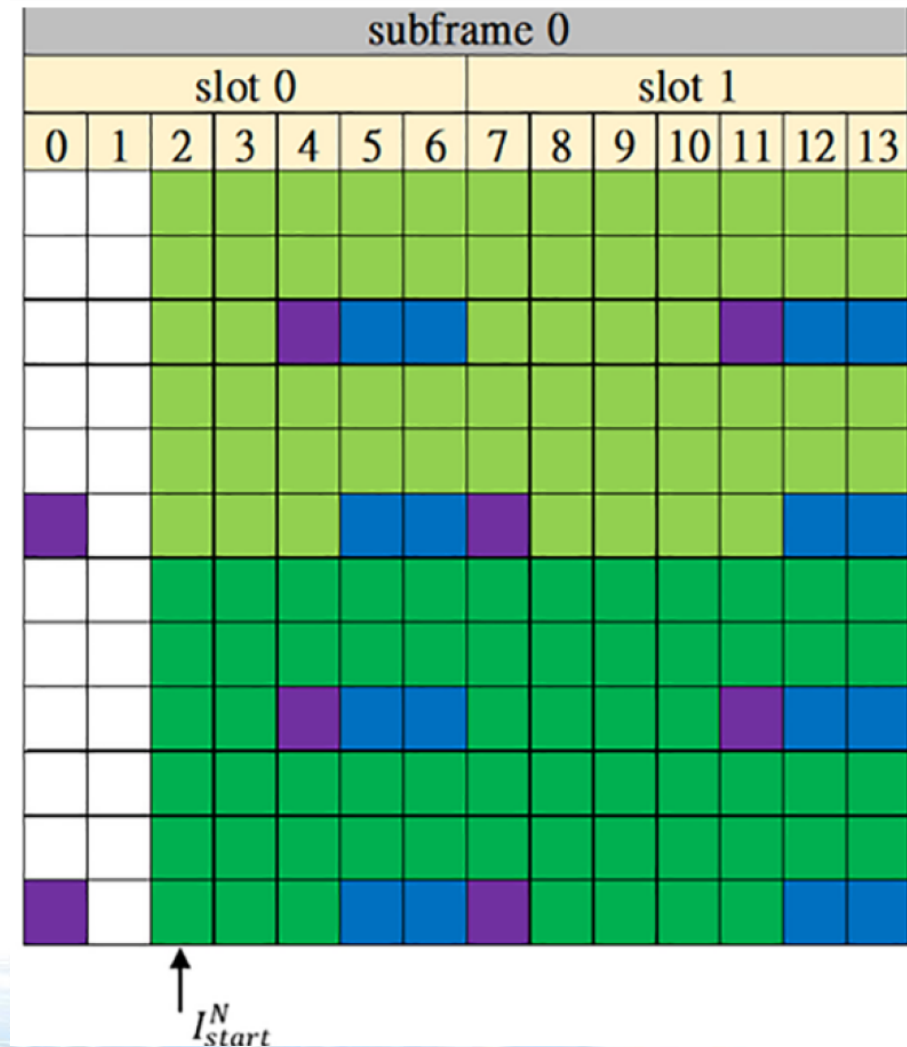



# NPDSCH

- Allocation of resource elements as NPDCCH format 1 (whole 180 kHz)
- Maximum **Transport Block Size (TBS)** is **680 bits**
- Transmitted over **NSF subframes**
- To extend base station coverage, NPDSCH also uses repeat transmission
- Each Transport block **repeat NRep times**
- Totally, **NSF x NRep subframes**

## Subframe mapping of NPDCCH and NPDSCH

- NB-IoT downlink transmission NO automatic ACK/NACK
- Base station needs ask at NPDCCH, the UE then will use corresponding NPUSCH format 2 to transmit ACK/NACK to base station



# NB-IoT Control Channel

- Uplink

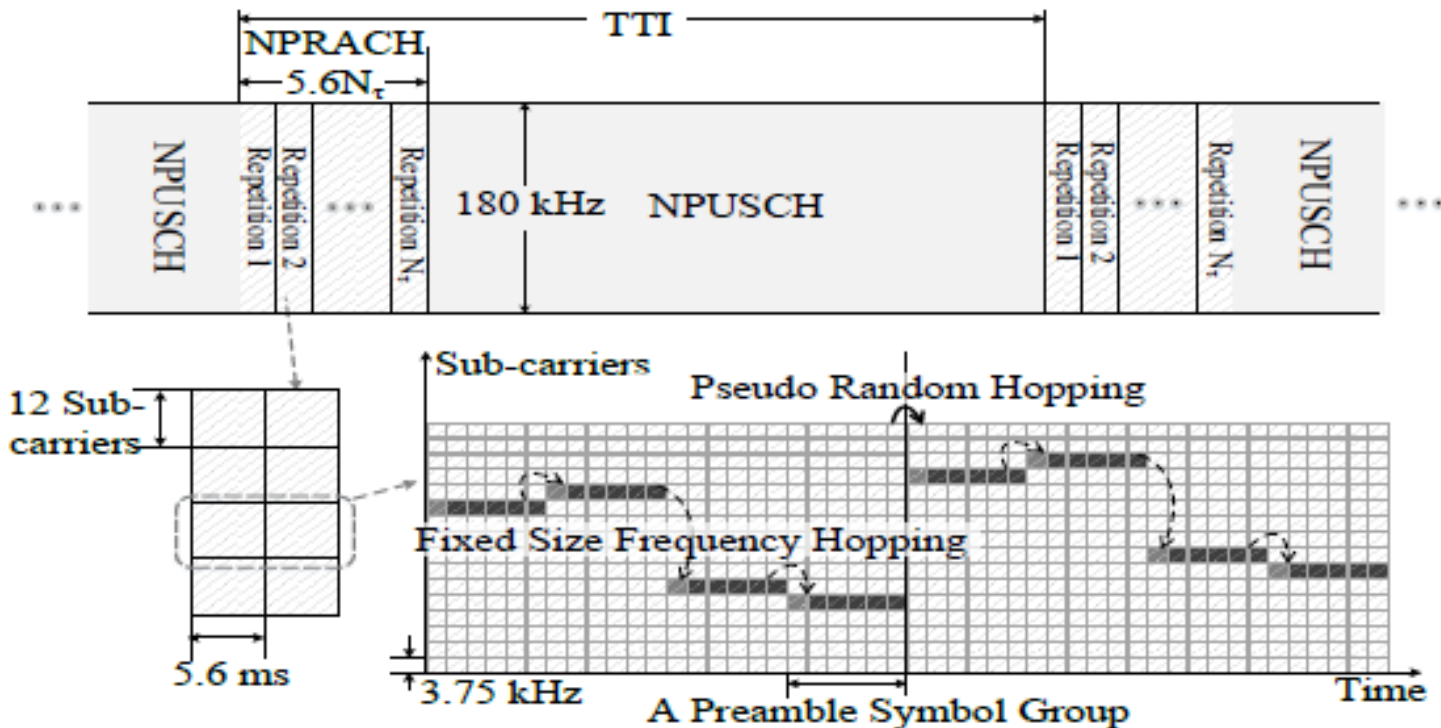

# NB-IoT Control Channel

- Uplink
  - Narrowband physical random access channel (NPRACH)
    - 一個NPRACH Preamble由四個Symbol group組成，每個Symbol group包含一個CP(Cycle Prefix)和五個Symbol。(四個Symbol group組成一個Preamble)
  - Narrowband physical uplink shared channel (NPUSCH)

CP:

Format0 : 66.67  $\mu$ s

Format1 : 267  $\mu$ s

$T_{SEQ} = 1.333$  ms,

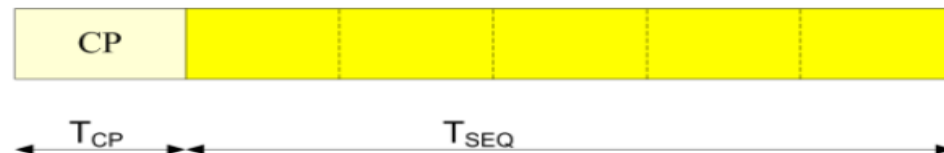



# NPUSCH

- Signal: LTE's Single-carrier Frequency-Division Multiple Access,
- SC-FDMA
- Subcarrier space: 15kHz or 3.5kHz
- Bandwidth = 180kHz (for in-band mode)
- A SC-FDMA symbol = 12 sub-carriers (15kHz) = 48 sub-carriers (3.5kHz)
- 1 timeslot = 7 SC-FDMA symbols = 0.5 ms(15kHz) = 2ms (3.5kHz)
- 1 sub-frame = 2 timeslots, 1 frame = 10 sub-frames





# NPUSCH

NPUSCH Format	Subcarrier Spacing	$N_{sc}^{RU}$	$N_{slots}^{UL}$	time(ms)	Modulation
Format 1	3.75 kHz	1	16	32	BPSK,QPSK
	15 kHz	1	16	8	BPSK,QPSK
		3	8	4	QPSK
		6	4	5	QPSK
		12	2	1	QPSK
Format 2	3.75 kHz	1	4	8	BPSK
	15 kHz	1	4	2	BPSK



# Uplink

- Signal Modulation: QPSK or BPSK
- To keep UE simple, only 1 antenna port
- After receive NB-MIB from NPBCH and SIB1-NB, SIB2-NB from NPDSCH, UE has all system parameters to transmit Random Access Preamble to base station
- To make a connection to base station



# NPRACH (Random Access Channel)

- Preamble Symbol Group
- Use 3.75kHz subcarrier = 48 subcarriers ( $3.75 \times 48 = 180$  KHz)
- Cyclic Prefix (CP) and 5 repeated symbols

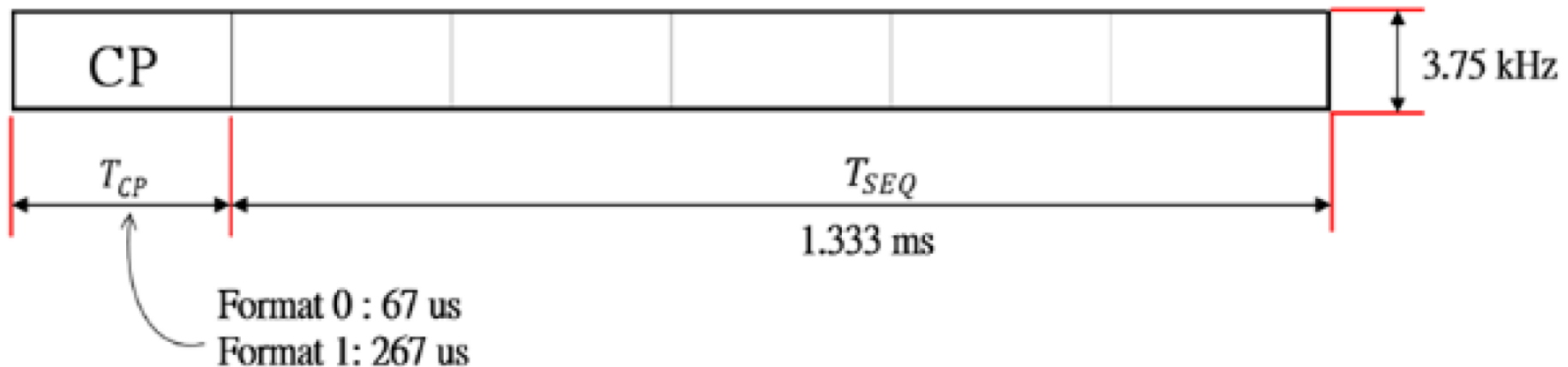

# Preamble of NPRACH

- Preamble of NPRACH consists of 4 continuous Preamble Symbol Groups
- For larger coverage, also uses repetition and frequency hopping
- Hopping range: 12, 24, 36, or 48 neighbor sub-carriers
- As long as start sub-carrier is different, then the following hopping will not have sub-carrier conflict

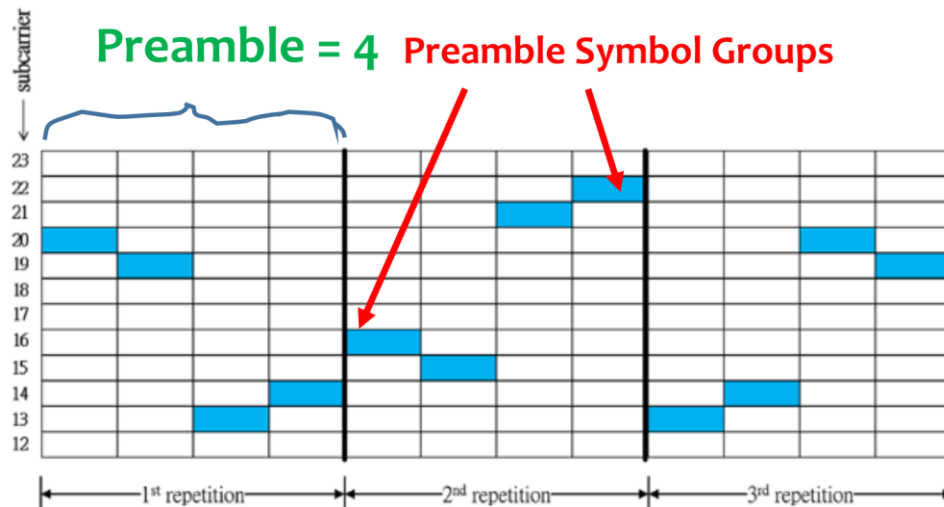



# DMRS (DeModulation Reference Signal)

- For base station's channel estimation and then demodulates NPUSCH correctly
- Format 1 (data): **1 DMRS** symbol in each slot
- Format 2 (ACK): **3 DMRS** symbols in each slot

# Format 1/2 DMRS symbol

Slot = 0.5ms

Format 1  
DMRS symbol

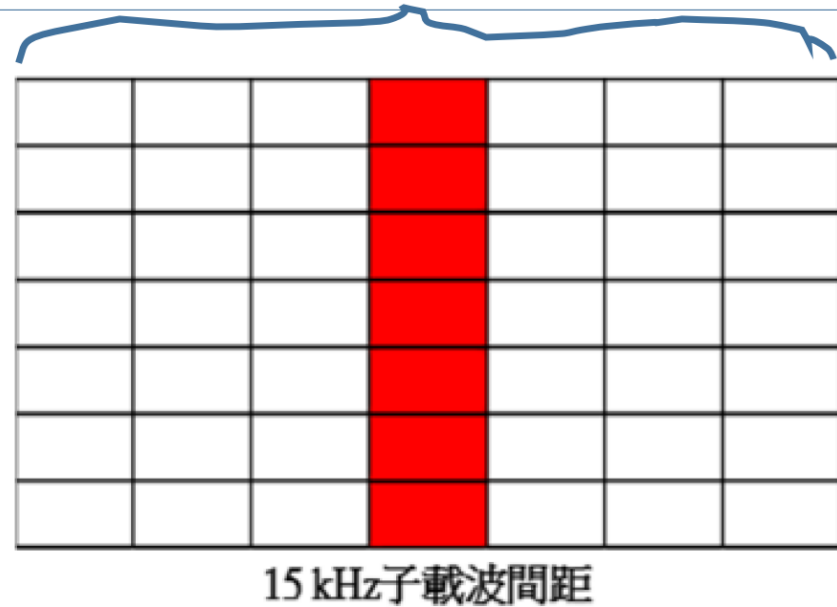
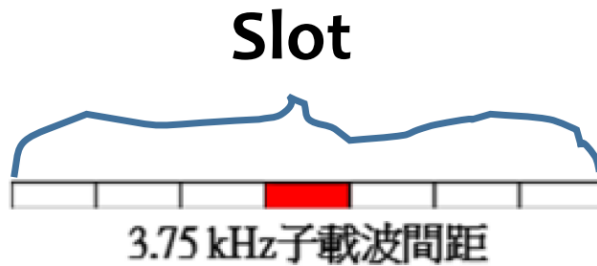

Format 2



# R14: Coverage Enhancement

- 為了滿足布建在細胞邊緣(Cell edge)或地下室等通道品質較低的UE，基地台與UE之間透過採用較少數量的子載波(Subcarrier)與將欲傳遞的資料作重複傳送(repetition)以利於接收端提高正確解出資料的成功率。
- 涵蓋範圍延伸(Coverage Enhancement Level, CE Level)共分為三種等級，分別為達到可對抗最大耦合損失(Maximum Coupling Loss, MCL)(從基站天線端口到終端天線端口的路徑損耗)，為144dB、154dB、164dB的訊號能量衰減。
- 基地台與NB-IoT UE間會根據所在的CE Level來選擇相對應的訊息重複傳送次數。

# Power Saving Mode

- 在IDLE態下再新增加一個新的狀態PSM（idle的子狀態），在該狀態下，終端射頻關閉，相當於關機狀態。
- 在PSM狀態時，下行不可達，DDN到達MME後，MME通知SGW緩存用戶下行數據並延遲觸發paging。
- 上行有數據要發送時，觸發終端進入連接態。
- 終端何時進入PSM狀態，以及在PSM狀態駐留的時長由核心網和終端協商。

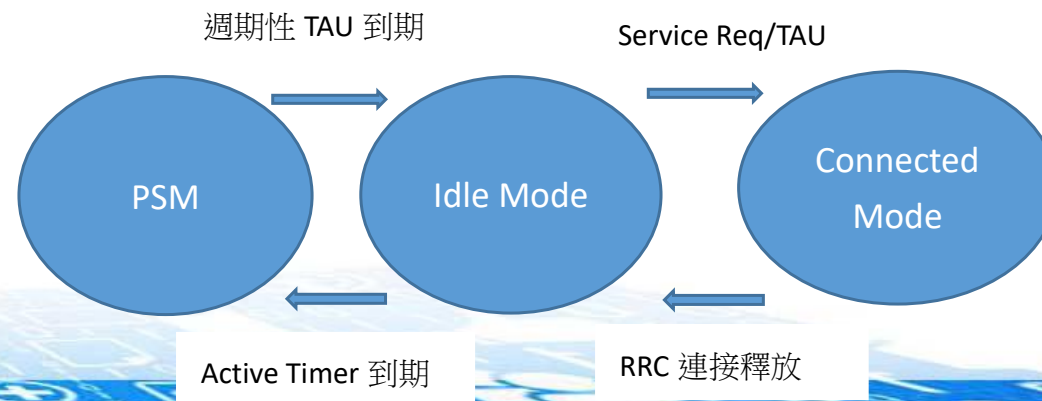



# Power Saving Mode

- 如果設備支持PSM（Power Saving Mode），在attach或TAU（Tracking Area Update）過程中，向網路申請一個Active Timer value(T3324，0-255 秒)。
- 當設備轉移到空閒後，該定時器開始運行。當定時器終止，設備進入省電模式。
- 進入省電模式後設備不再接收paging消息。
- UE進入PSM模式後，只有在UE需要發送MO數據，或TAU/RAU定時器超時後，才會退出PSM模式。
- TAU最大周期為310小時。



# PSM

54分鐘到310小時

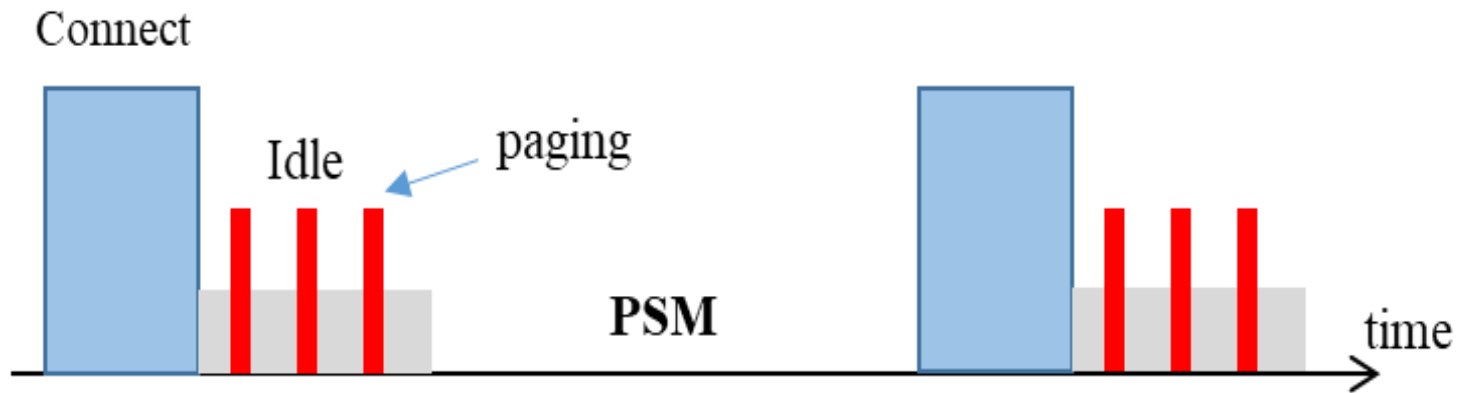
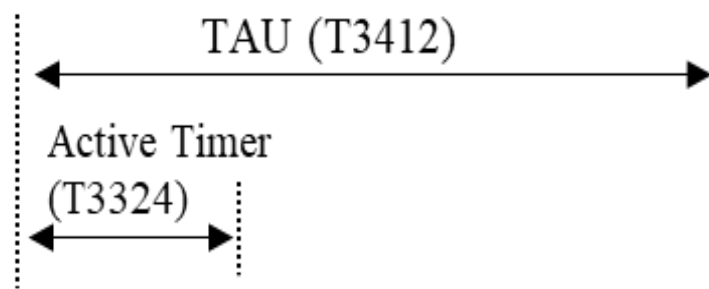

# eDRX (Extended DRX)

- eDRX(Discontinuous Reception) 狀態被分為空閒態和連接態兩種。
- eDRX 的尋呼週期由網路在 ATTACH 和 TAU 消息中指定（ UE 可以指定建議值 ），可為10.24秒到2.92小時。
  - 每個eDRX週期包含一個PTW週期(2.56秒到40.96秒)和PSM週期，在PTW週期內，有多個DRX週期(1.28秒到10.24秒)
- 相比以往 1.28s/2.56s 等 DRX 尋呼週期配置， eDRX 耗電量顯然低很多。

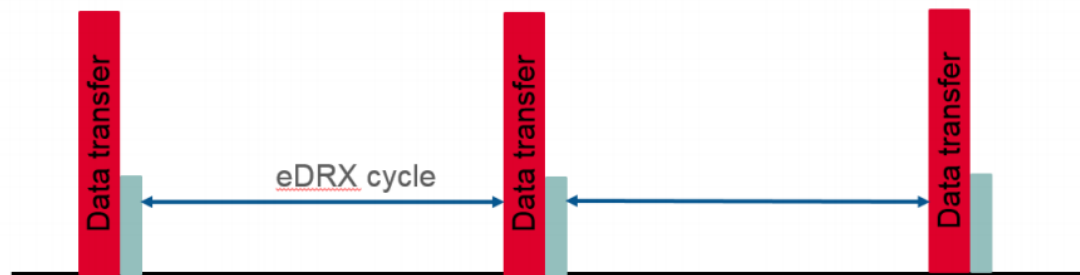

# eDRX

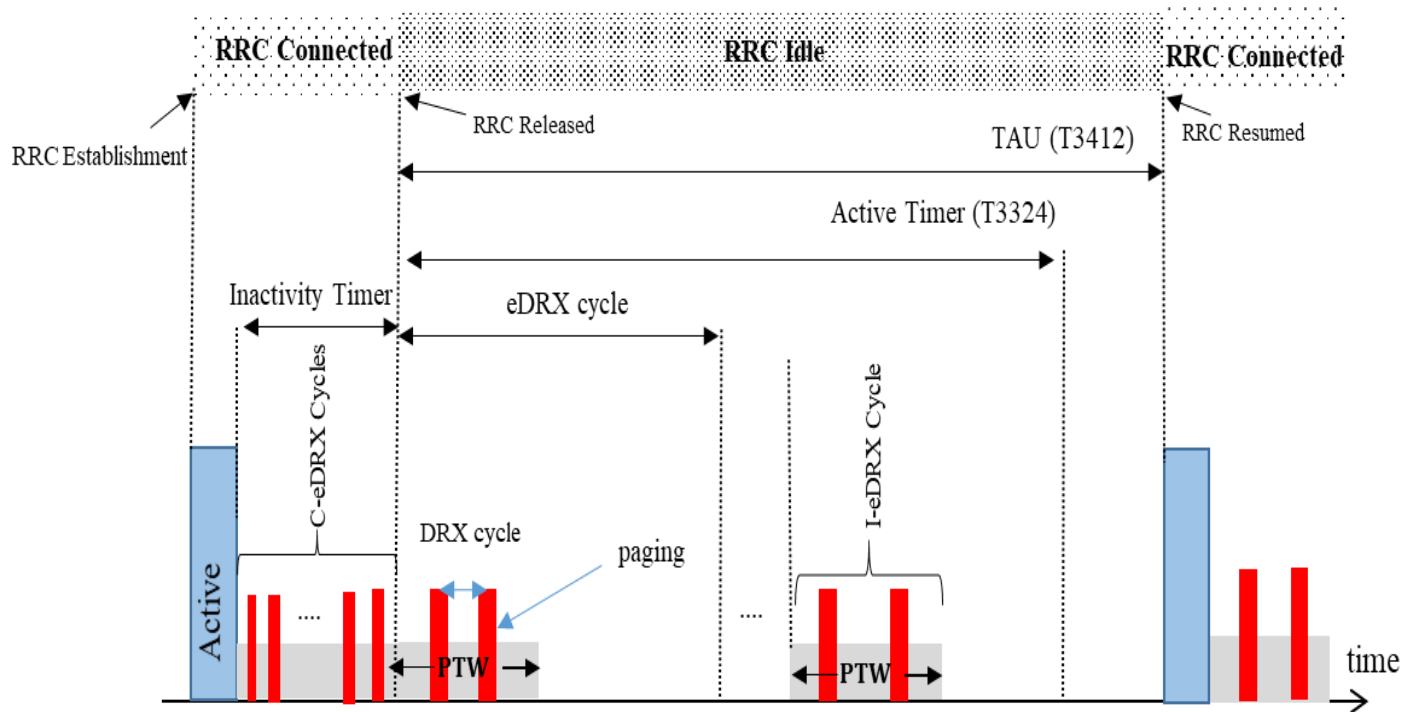

# Data piggyback in NAS message

- 對於NB-IoT UE而言，與系統連線可能僅為傳遞一筆微量資料，卻須先建立無線資源控制連線，之後再進行兩道回報程序才可進行資料傳遞。
- NB-IoT UE需更有效率的微量資料傳遞機制。在R13技術規格特別新定義了一組夾帶在無線資源控制連線請求訊息中，稱為資料數值與功率餘裕(Data Value and Power Headroom, DV and PH)的介面存取控制層資訊元素(Medium Access Control Information Element, MAC IE)。
- 該資訊元素物理意義與功能等同於BSR與PHR兩道程序，數值的表示方式也相似於既有的BSR與PHR，皆是使用查表。

Index	Data Volume (DV) value [bytes]	Index	Data Volume (DV) value [bytes]
0	DV = 0	8	67 < DV <= 91
1	0 < DV <= 10	9	91 < DV <= 125
2	10 < DV <= 14	10	125 < DV <= 171
3	14 < DV <= 19	11	171 < DV <= 234
4	19 < DV <= 26	12	234 < DV <= 321
5	26 < DV <= 36	13	321 < DV <= 768
6	36 < DV <= 49	14	768 < DV <= 1500
7	49 < DV <= 67	15	DV > 1500

# R14: Anchor載波卸載任務

- NB-IoT UE是被限制僅能於Anchor載波上進行隨機存取程序以及聆聽Paging訊息。
- 此外，窄頻物理廣播通道(Narrow Band Physical Broadcast Channel, NPBCH)、窄頻主要同步訊號與窄頻次要同步訊號皆也被承載在Anchor載波上。
- 但窄頻物聯網隨機存取通道(NB-IoT Random Access Channel, NPRACH)中訊息傳送相當占用資源與窄頻物聯網使用者裝置數量龐大的情況下，相較於Non-Anchor載波，Anchor載波負擔了相當可觀之訊務量。
- 為了要減輕Anchor載波的負載量，R14採取了讓基地台於Non-Anchor載波也可以配置窄頻物理隨機存取通道與Paging訊息的設計。

# NB-IoT建置

- 國內四家電信公司，包括中華電信、遠傳、台灣大哥大、亞太電信均已於2017年投入建置NB-IoT的實驗室與測試平台，預計2018年第二季後將陸續在商用頻段進行測試。
- 2017年11月電信三雄(中華電信、遠傳、台灣大哥大)獲得「040開頭」300萬門物聯網專用門號，台灣電信物聯網正式開跑。
- 國家通信傳播委員會（NCC）於2018年1月公告「行動寬頻業務窄頻終端設備技術規範」（PLMN11），針對具有NB-IoT或CAT-M1功能的產品，須取得型式認證始能於台灣合法販售。

# 中華電信NB-IoT

- 中華電信在2017/7/14發佈新聞稿指出中華電信研究院已自主研發完成國內第一套NB-IoT整合型閘道器，及符合國際OCF及國內家電TaiSEIA 101產業標準之IoT平台。
- 2018年1月開放免費公測，年底正式推出商用服務。
  - 同時提供NB-IOT及CAT-M1
  - 採用主流頻段(900MHz/1800MHz)
  - IoT智慧聯網大平台
- 除NB-IoT基地台外，亦完成具NFV (Network Function Virtualization)功能之核心網路。



# 中華電信IoT智慧聯網大平台

1 大平台、2 類介面、3 個核心、4+ 個領域、5 種智慧

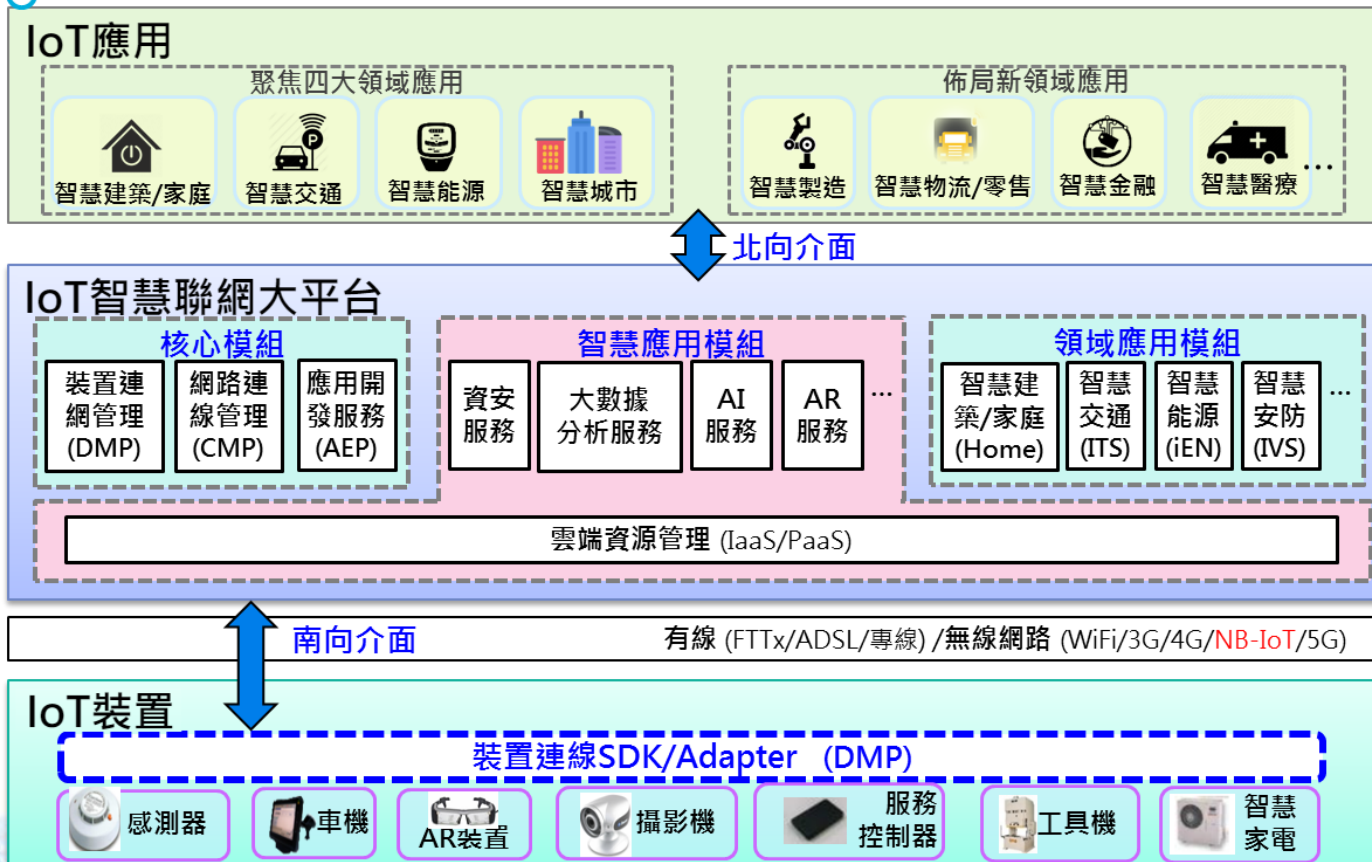

# 中華電信IoT智慧聯網大平台

- 3核心服務
  - DMP 裝置連網管理: 事件偵測連動
  - CMP 網路連線管理: 4G、NB-IoT
  - AEP 應用開發服務: APP框架、圖控
- 4領域服務
  - iEN 能源: 用電專家診斷、能源計量
  - ITS 交通: 車隊管理、TTIA 營業大客
  - eHOME 建築/家庭: 智慧家電標準
  - IVS 安防: 影像串流、ONVIF協定
- 5智慧服務
  - Big Data 大數據: 即時分析應用分析
  - Block Chain 區塊鏈: 重要交易資料存證
  - Security 資安: PKI雙向認證
  - AI 人工智慧: 語音合成、人臉辨識
  - AR 擴增實境: 遠端智慧協作

# 遠傳電信NB-IoT

2017



# 遠傳電信NB-IoT

2018

NB-IoT工業區商轉應用案例  
正式啟航

Jan.

- 超過200家上下游軟硬體夥伴加入遠傳NB-IoT測試
- 與國際電信業者3HK成功完成NB-IoT漫遊測試
- 完成全台60%的NB-IoT網路涵蓋
- 於『智慧城市展』展示NB-IoT多元應用-智慧路燈、智慧停車、智慧門鎖、販賣機聯網、環境監測、全球連線管理平台應用
- 全球連線管理平台(CMP, Connectivity Management Platform)上線

- NB-IoT全台涵蓋
- 提供國際漫遊服務

上半年NB-IoT網路訊號  
全台涵蓋

# 遠傳電信NB-IoT

方案類型	輕量型	重量型	勁量型
月租費	\$10	\$25	\$60
免費傳輸量	5MB	15MB	40MB
適用上傳頻率 (*5KB/次)	每小時/次	每15~30分/次	每5分/次
適用領域	瓦斯錶	販售機庫存偵測	資產追蹤
	智慧路燈/照明	事務機監控	車聯網
	空氣品質偵測	健康偵測	機器控制
	火災偵測	智慧家電	停車格偵測
	消警器	智慧農業	跌倒偵測
	電量監測	智慧養殖	太陽能發電管理

# NB-IoT Module Status

Item	模組商	國家	模組型號	支援頻段	使用晶片	連線測試
1	Quectel 上海移远通信	大陸	BC95-B28	Cat NB1; B20,B28	華為Boudica 120	測試通過
2	u-blox	瑞士	SARA-N280	Cat NB1; B28	華為Boudica 120	測試通過
3	Sierra wireless	加拿大	WP7700	Cat M1& NB1; B1, B2, B3, B4, B5, B8, B12, B13, B17, B18, B19,	Qualcomm MDM9206	測試通過
4	SIMCOM 芯讯通无线科技	大陸	SIM7000E	Cat M1& NB1; Band 3 ,Band 8 ,Band 20 ,Band 28	Qualcomm MDM9206	測試通過
5	Askey 亞旭	台灣	WWHC091	Cat NB1& M1 ; B1,B2,B3,B4,B5,B8,B12,B1 3,B17,B18,B19,B20,B28	Qualcomm MDM9206	測試通過
6	Lierda 利爾達	大陸	NB05-01	Cat NB1 ; B8,B5,B28	華為Boudica 120	測試通過
7	海華科技 (和碩子公司)	台灣	AW-BM334SM	Cat NB1; B1,B2,B3,B5,B8,B12,B13,B 17,B18,B19,B20,B26,B28	華為Boudica 150	測試通過





# Non 3GPP LPWAN

# LoRa Alliance

- LoRa Alliance
  - Open & Non-Profit, Founded: March 2015
  - Board: IBM, Cisco, HP, Semtech, ...
- Specification: LoRaWAN R1.1
- 30+ Announced Deployments
  - Taipei's open IoT platform







# LoRa Alliance

- RF Band: Sub 1G
- Modulation: Chirp Spread Spectrum or FSK
- Data rate: 250 ~ 50k bps (adaptive)
- Range: urban 2-5km, suburban 15 km, rural 45km
- Lower Power: estimated 10 years with two AAA batteries (end node)



# LoRa and LoRaWAN

- LoRa<sup>®</sup> physical layer enables the long- range communication link.
- LoRaWAN defines the communication protocol (MAC) and system architecture for the network

Source: LoRa Website



# LoRaWAN (1)

- Target key requirements of Internet of things such as secure bi-directional communication, mobility and localization services.
- Typically laid out in a **star-of-stars topology** in which **gateways are transparent bridges relaying messages between end-devices and a central network server** in the backend.
- All end-point communication is generally bi-directional, but also supports operations such as multicast, **enabling software upgrade over the air or other mass distribution messages** to reduce the on-air communication time.

Source: LoRa Website

# RoLa Architecture

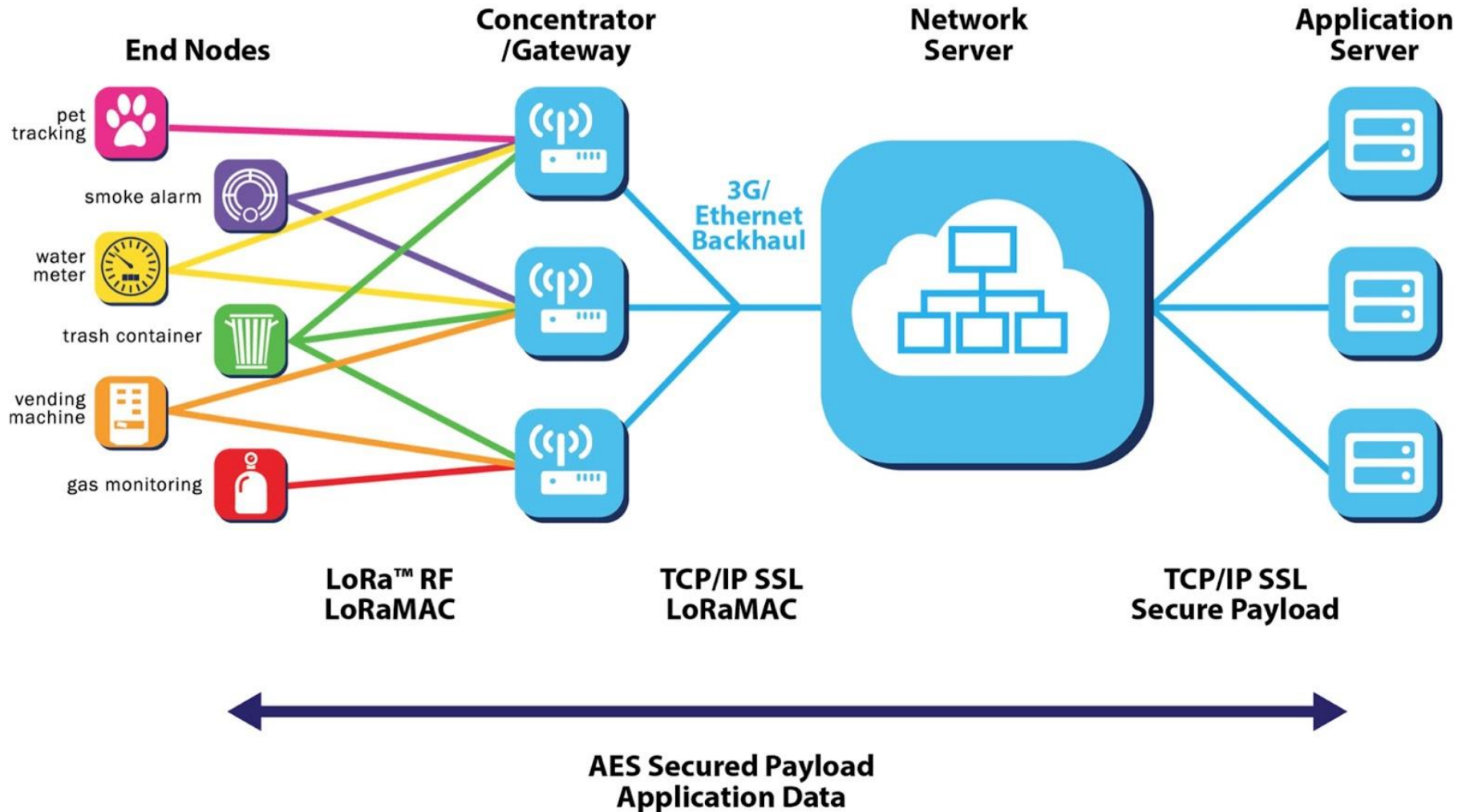



## LoRaWAN (2)

- Communication between end-devices and gateways is spread out on different frequency channels and data rates.
- **Data rates range from 0.3 kbps to 50 kbps.**
- The LoRaWAN network server is managing the data rate and RF output for each end-device individually by means of an **adaptive data rate (ADR)** scheme.



# LoRaWAN (3)

- LoRa® (Long Range) is the physical layer or the wireless modulation utilized to create the long range communication link.
- Frequency shifting keying (**FSK**) modulation to achieve low power.
- Chirp **spread spectrum** modulation to increase the communication range.
- Secure communications by several layer of encryption: Unique **Network key** (EUI64) on network level, Unique **Application key** (EUI64) for end to end security on application level and **Device specific key** (EUI128).

Source: LoRa Website



# LoRaWAN Protocol

- The protocol and network architecture have the most influence in determining
  - the battery lifetime of a node,
  - the network capacity,
  - the quality of service,
  - the security, and
  - the variety of applications served by the network.

# LoRaWAN Protocol

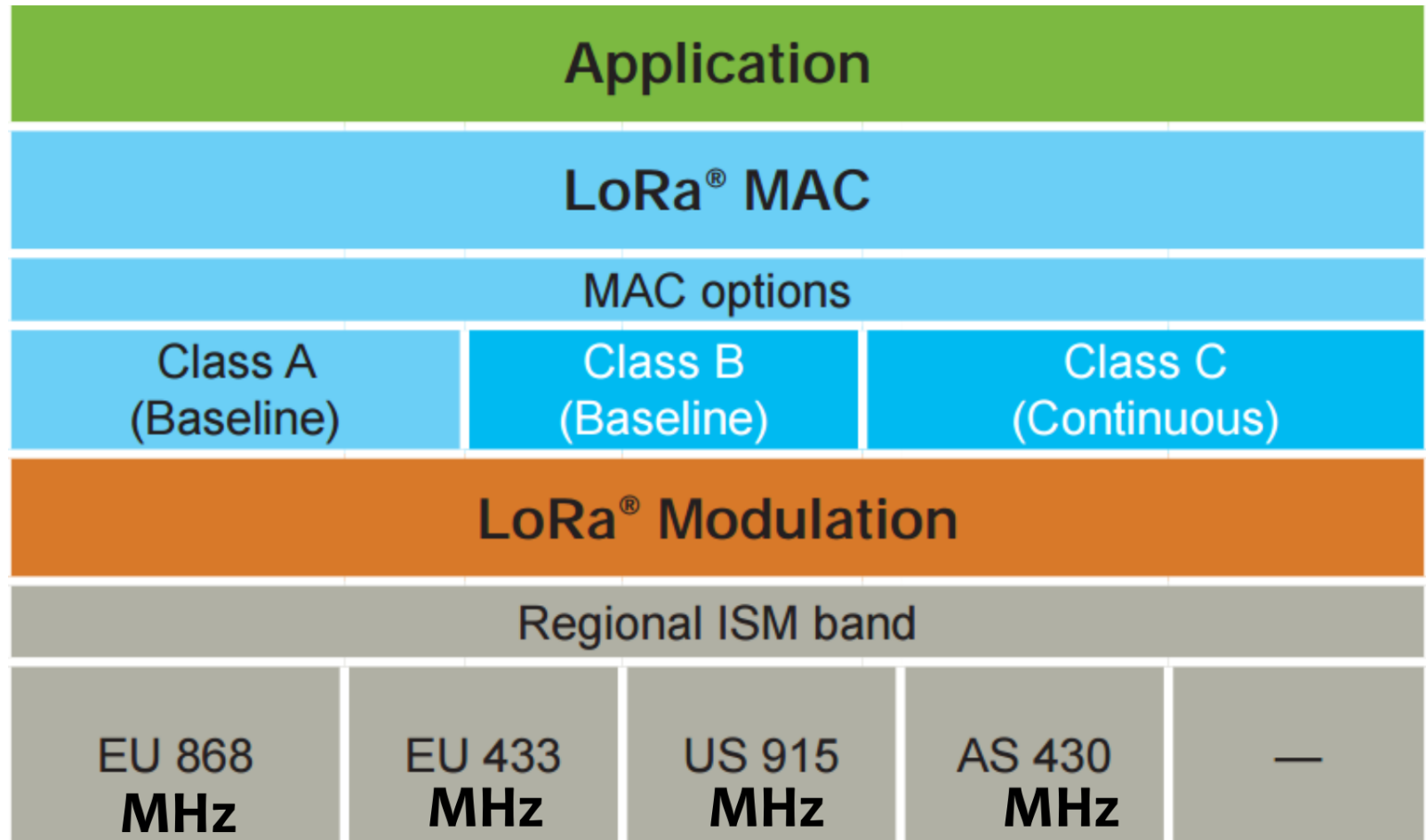





# LoRaWAN Protocol

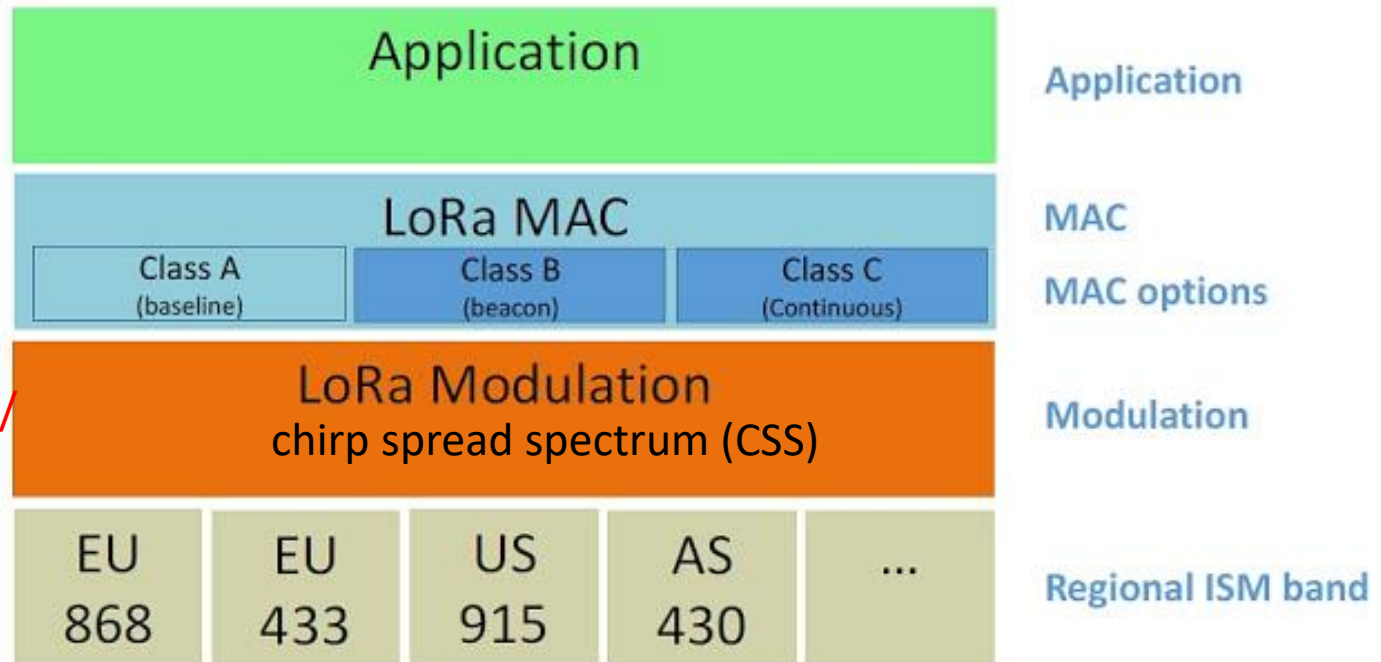

Forward Error Correction (FEC) w/ spread spectrum



# Network Capacity

- If a node has a good link and is close to a gateway, it can use higher data rate.
- The time on air is then shortened.
- Adaptive data rate also optimizes the battery lifetime of a node.
- A network can be deployed with only ONE gateway first, and as capacity is needed,
  - Adding more gateways

# Adaptive Data Rate (ADR)

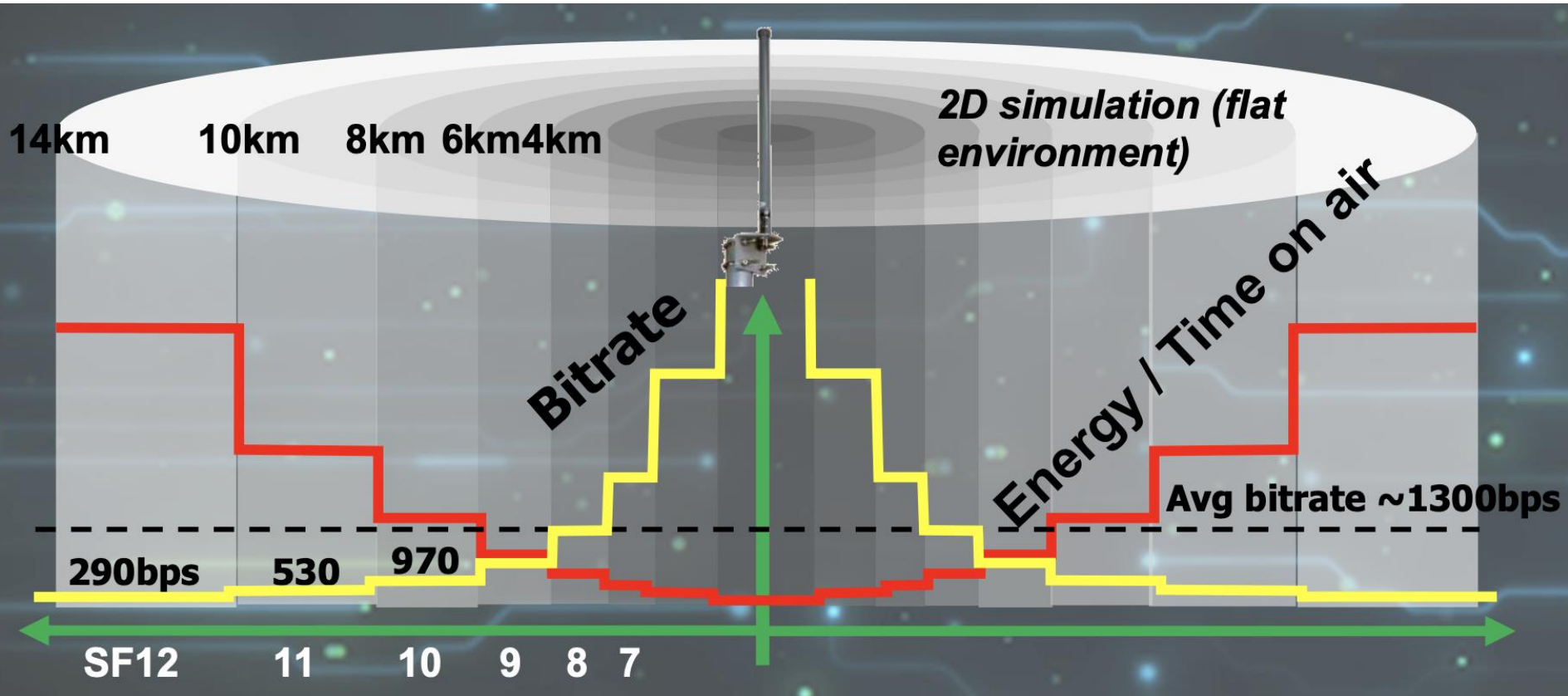

# LoRaWAN Device Classes

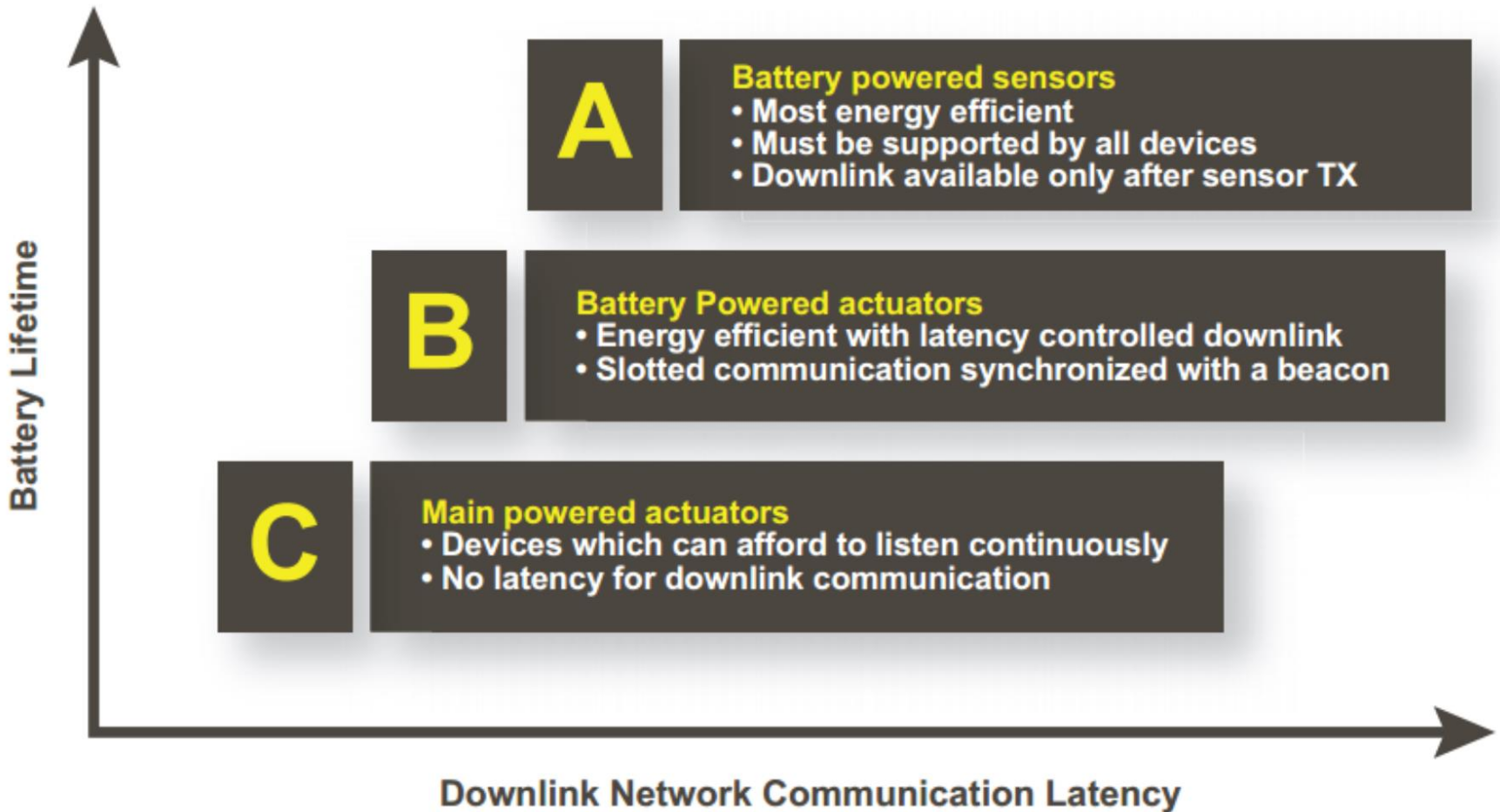



# LoRaWAN Device Classes

- Support three **classes of end-point devices**:
  - **Bi-directional end-devices (Class A)**: Devices require downlink communication from the server shortly after the end-device has sent an uplink transmission.
  - **Bi-directional end-devices with scheduled receive slots (Class B)**: In addition to the Class A random receive windows, Class B devices open extra receive windows at scheduled times.
  - **Bi-directional end-devices with maximal receive slots (Class C)**: End-devices of Class C have nearly continuously open receive windows.

Source: LoRa Website



# Class A end devices

- Bi-directional end-devices (Class A):
  - Uplink transmission is followed by two short downlink receive windows.
- Random time basis (ALOHA-type) protocol.
- The lowest power end-device system
- Downlink communications from the server will have to wait until the next scheduled uplink.

# Class A end devices

**For every uplink, there are two possible downlink slots. Downlink is possible only at these times.**

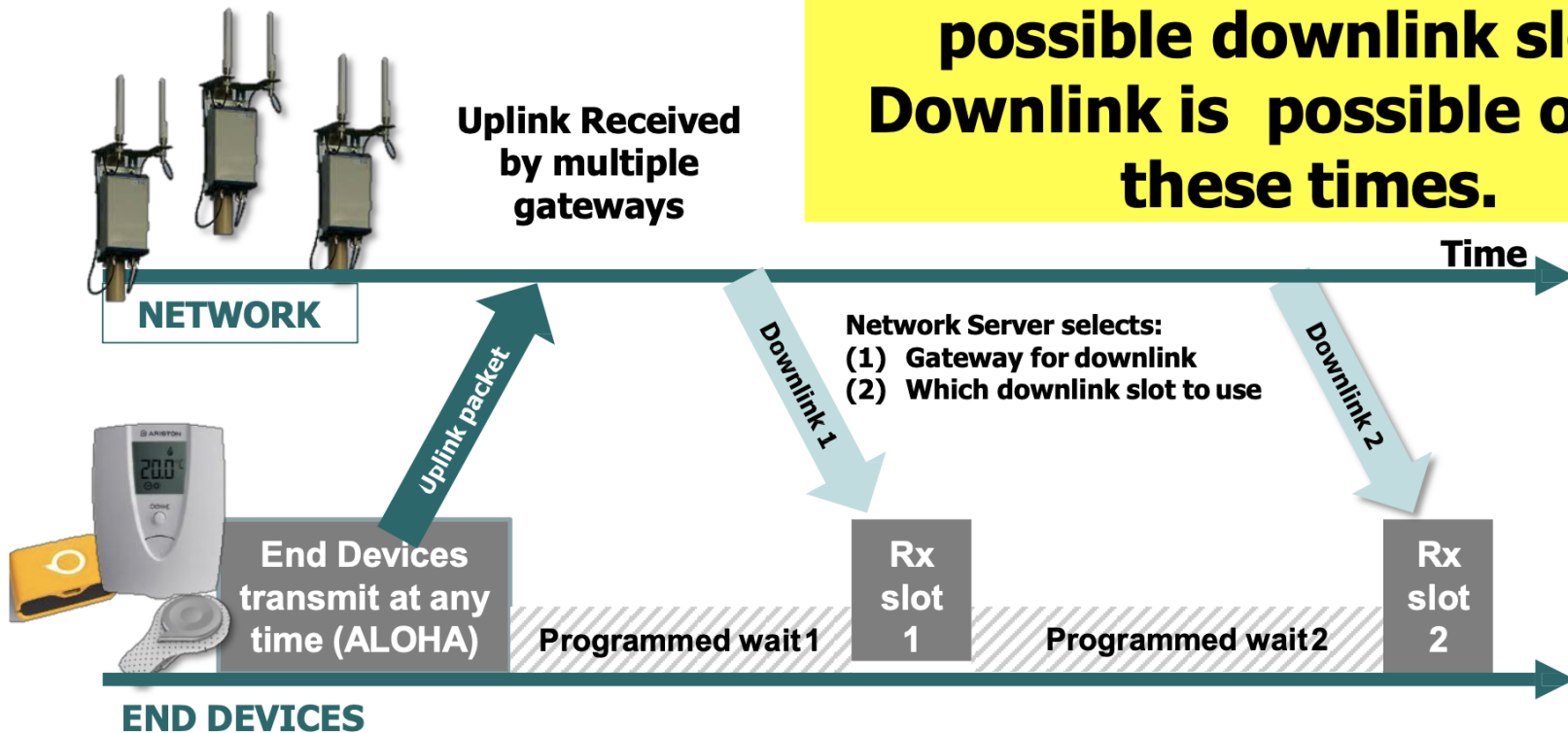

***Receiver Initiated Transmission strategy (RIT)***



# Class B end devices

- Class B devices open extra receive windows at scheduled times.
- It receives a time-synchronized beacon from the gateway.
- This allows the server to know when the end-device is listening.



# Class B end devices

**There are pre-programmed downlink slots. Downlink is possible at any of these times. Application dependent.**

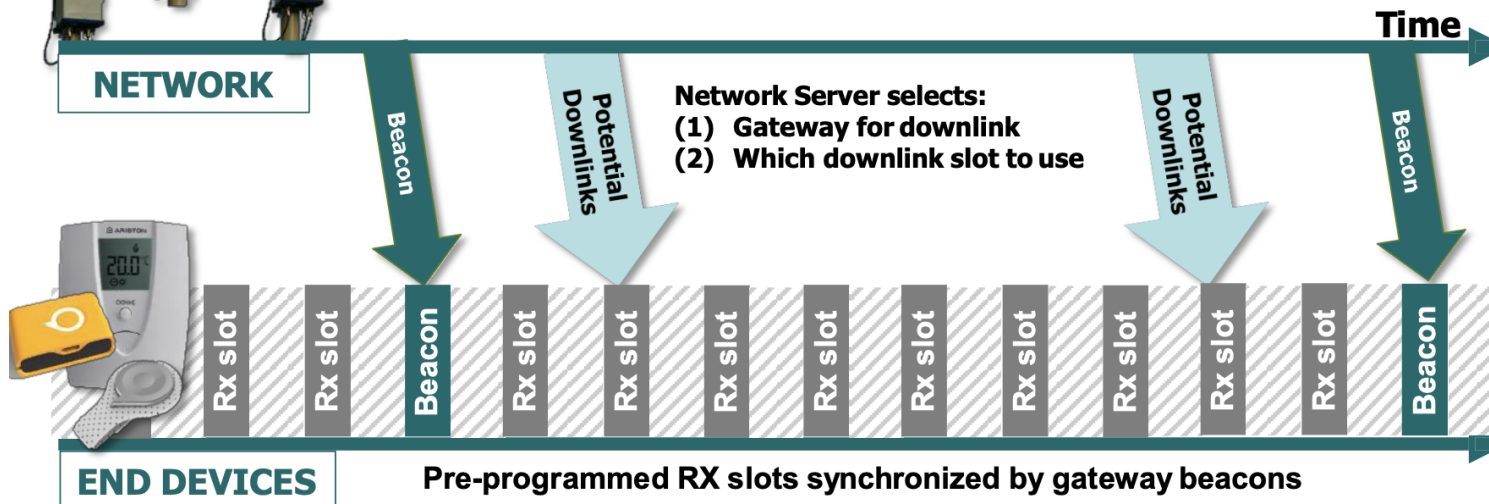

***Coordinated Sampled Listening (CSL)***



# Class C end devices

- Bi-directional end-devices with maximal receive slots.
- End-devices of Class C have almost continuously open receive windows, only closed when transmitting.

# LoRa Network Server

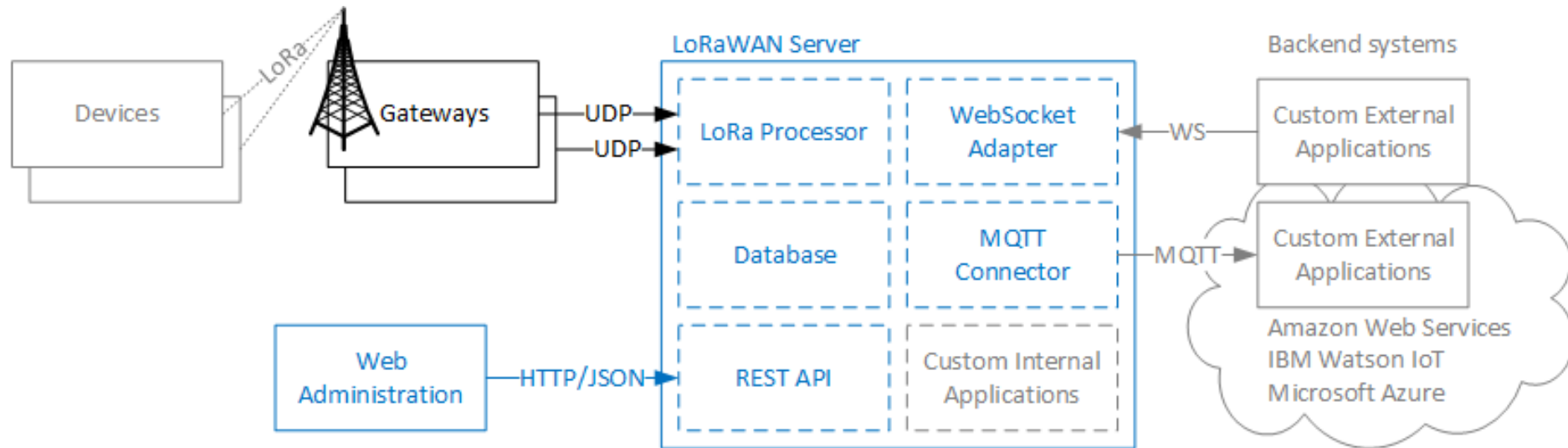

# LoRa Coverage

## Countries — LoRaWAN™ Networks

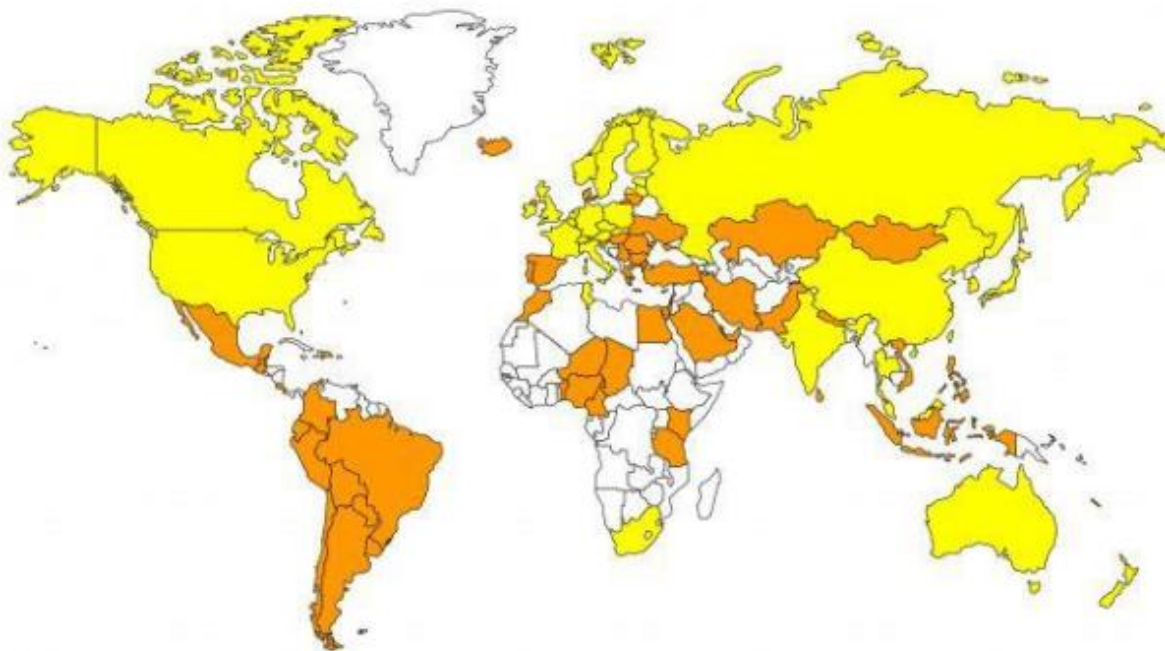

- 42 Publicly Announced Operators
- 30 Alliance Member Operators
- 250+ on-going trials & city deployments
- 480+ members in the Alliance

Legend:

- Publicly Announced
- Other Deployments

# SIGFOX

## A NETWORK DESIGNED FOR MASS IOT

### RESISTENCE TO INTERFERENCE



400 100Hz channels  
random choose 3 channels  
transmitted multiple times

- Narrowband is the de-facto standard for long range reliable connections in noisy spectrum
- Extremely low rate of collision

### LARGE COVERAGE

- High sensibility
  - Base Station sensitivity: -142dBm
  - **Link Budget Sigfox**  
 $14+3+142 = 159 \text{ dB}$  Link Budget



- High Device density thanks to optimized low data rate

### POWER EFFICIENCY

- For long life cycle Devices:
  - Short messages, low data rate
  - Awakes only for transmit
  - Leading edge low power technologies by Silicon Partners
- Network
  - Very low collision rate, no retransmission
  - High Base Station sensitivity

### LOW COST DEVICES

- Free IP
- Leading edge Silicon vendors
- No specific chipset, benefiting of the volume scale
- Very low memories foot print (short message, protocol)

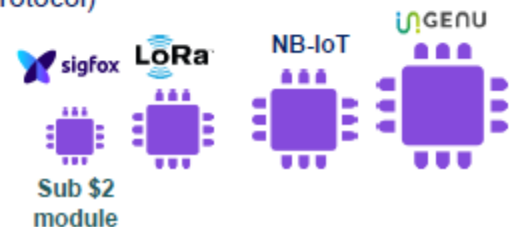



# SIGFOX

- SIGFOX provides a tailor-made solution for low-throughput IoT/M2M applications.
- Designed for IoT/M2M devices **characterized** by:
  - **Up to 140 messages per device per day**
  - **Payload size for each message is 12 bytes**
  - **Wireless throughput up to 100 bits per second**
- Based on Ultra-Narrow Band (UNB) technology such as unlicensed ISM radio bands (in Europe, 868MHz; in the US, 915MHz)
- Cellular scope at an average range of about **30-50km** in rural areas and in urban areas **between 3 and 10km**.
- Deployment in Netherlands, France, the UK, Spain and San Francisco in the US.

# SIGFOX Coverage

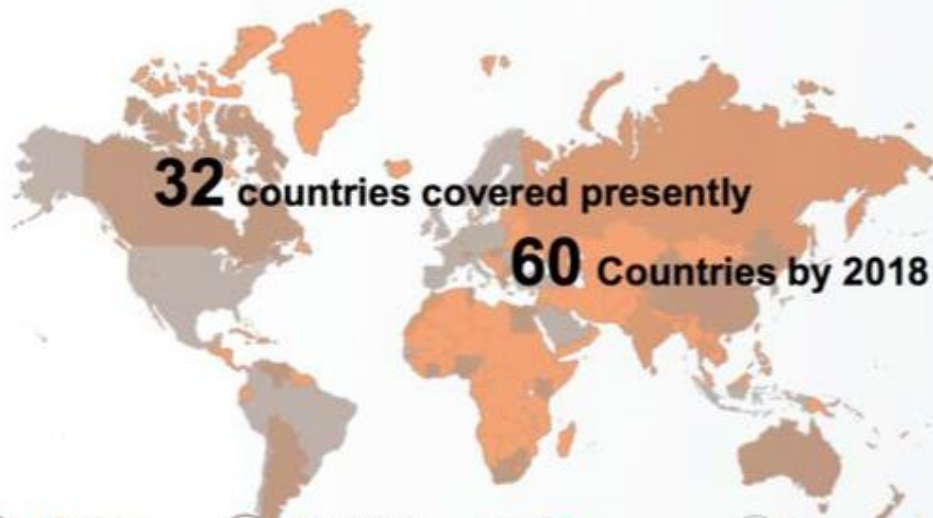

Global Reach & Highly Scalable

Started in France in 2009  
Most mature LPWAN technology worldwide  
1.9 million km<sup>2</sup>  
486 million people covered  
7 million devices booked on the network

# LoRa vs. SigFox

	SIGFOX	LoRaWAN
<b>Modulation</b>	UNB DBPSK(UL), GFSK(DL)	CSS
<b>Band</b>	SUB-GHZ ISM:EU (868MHz), US(902MHz)	SUB-GHZ ISM:EU (433MHz 868MHz), US (915MHz), Asia (430MHz)
<b>Data rate</b>	100 bps(UL), 600 bps(DL)	0.3-37.5 kbps (LoRa), 50 kbps (FSK)
<b>Range</b>	10 km (URBAN), 50 km (RURAL)	5 km(URBAN), 15 km (RURAL)
<b>Num. of channels / orthogonal signals</b>	360 channels	10 in EU, 64+8(UL) and 8(DL) in US plus multiple SFs
<b>Link symmetry</b>	✗	✓
<b>Forward error correction</b>	✗	✓
<b>MAC</b>	unslotted ALOHA	unslotted ALOHA
<b>Topology</b>	star	star of stars
<b>Adaptive Data Rate</b>	✗	✓
<b>Payload length</b>	12B(UL), 8B(DL)	up to 250B (depends on SF & region)
<b>Handover</b>	end devices do not join a single base station	end devices do not join a single base station
<b>Authentication &amp; encryption</b>	<del>encryption not supported</del>	AES 128b
<b>Over the air updates</b>	✗	✓
<b>SLA support</b>	✗	✗
<b>Localization</b>	✗	✓



# DBPSK

## Differential BPSK

- 0 = same phase as last signal element
- 1 = 180° shift from last signal element

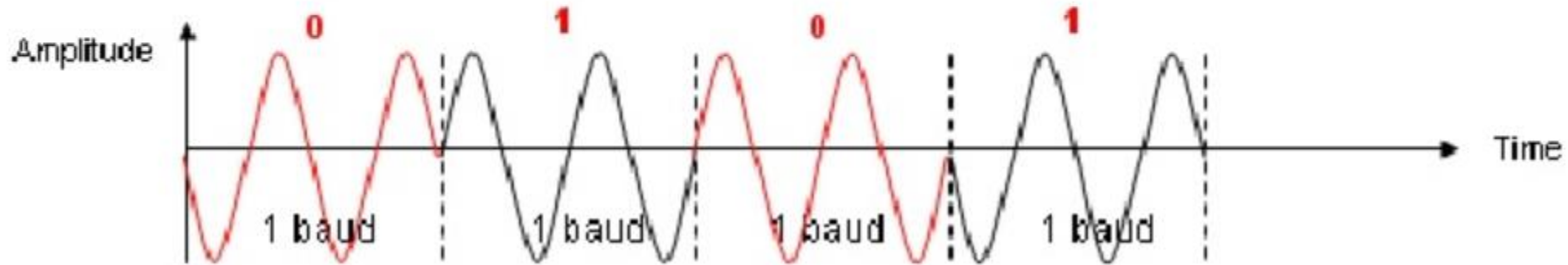



# Neul

- Neul provides a highly-scalable ubiquitous wide area wireless connectivity solution, providing deep indoor coverage, **10-15 year battery life** at low cost and the ubiquity of security without awkward configuration.
- Based on Weightless-N (based on ISM bands), also a UNB technology.
- Deployed and trialed in Milton Keynes of the UK.
- Acquired by Huawei on September 22, 2014 at \$25M.



	LoRa	NWave	Neul	Sigfox
Architecture & Topology	Star-of-stars topology	Star Topology	Star Topology	Star Topology
Wireless Technologies *Adaptive Data Rate	Spread spectrum, ADR* 0.3-50kbps, ISM band, point-to-point and multicast	UNB, Nwave <b>software-defined radio</b> , in sub-GHz license-exempt spectrum	ISM band (868/902MHz), TV white space, or licensed sub-GHz	UNB, ISM band, payload 12 bytes, up to 100 bps, Sigfox protocol
Base Station Functionality	3~8/15~45 Km, 1M nodes	10~30 Km, 1M nodes	NeulNET, 10 Km	3~10/ 30 ~50Km/1Mn
BS and Device Cost	<b>B \$4980 Euros</b> <b>3 class devices</b>	D < \$8	D (Iceni) \$4	<b>B 3000 Euros</b> <b>D &lt; US\$3</b>
Security Support	Network/application/device keys	NWave security	AES	AES
Backend Support	Backend server	Backend server	<b>Data cloud</b> (NaaS), billing, DM, OSS/BSS	Sigfox OSS/BSS
Applications	Healthcare, Tracker, agriculture, lighting	Smart parking, smart meter, smart agriculture	Waste mgmt., Pest control, wind energy	Car theft detector, water meter, valve control
Standards	LoRaWAN	Weightless-N, 30k~100k bps	Weightless-N, -W, -P (P: 16Mbps)	
Deployment Field	USA, France, Netherlands	London, UK	Smart city - Milton Keynes, UK	Netherlands, France, UK, Spain and USA

# Comparion among LoRaWAN, NWave, Neul and Sigfox



# Summary

- LPWAN is emerging as the key technology of the M2M Core network.